

Weldclass®

WELDING PRODUCTS CATALOGUE



AUSTRALIAN SINCE 1979

Weldclass®

THE WELDCLASS MISSION

Make life easier for welders and retailers.

At Weldclass, the work of improving our service, systems and products never stops. And it's all about keeping things simple and customer friendly.



WHY WELDCLASS ?

1. Easy to Deal With

A customer-friendly approach, clear communication, and a helpful team.

2. Support

From easy-to-understand product information, packaging, and displays to helpful tools, resources, and after-sales support - Weldclass empowers distributors and end-users to move with speed and confidence.

3. Market-Leading Products

That are reliable and perform at the top of their class. Weldclass is not 'just another welding supplier' and we don't just 'bring in stuff'. Behind every product range lies years of development, research, testing and perfecting.

4. Stock Availability

The best products in the world are not worth much if you can't get supply when you need it. We've set ourselves to provide the welding industry's best supply rate (typically above 95%) and you can check up on our progress at weldclass.com.au/supplyometer.



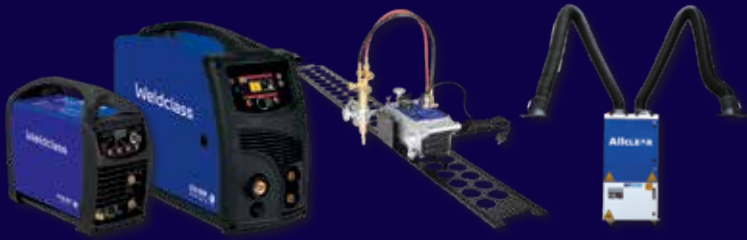

MACHINES

3



SAFETY & PROTECTION

19



CONSUMABLES

45

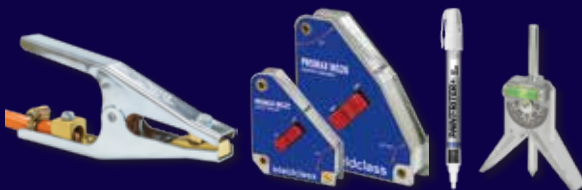

ACCESSORIES & TOOLS

57



TORCHES & SPARES

67

MIG, TIG, PLASMA

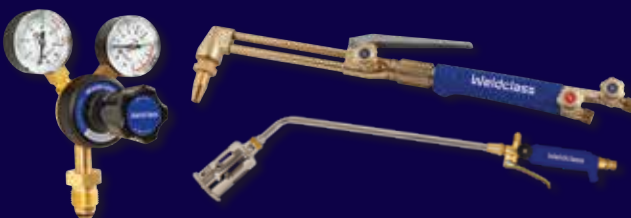

GAS GEAR

85



ABRASIVES

97



MERCH

103

Weldclass®



WELDCLASS.COM.AU

Your Destination For:

- ✓ Comprehensive product info
- ✓ Handy tools & reference guides
- ✓ Welding knowledge

And much more!





MACHINES



New Product Coming Soon

FORCE 160MST MK2 MIG | STICK | TIG



-  **160A output**
Max MIG capacity 6mm steel
-  **H/Duty Euro-connect MIG torch**
-  **10A plug**

- Plus**
- ✓ Very compact & lightweight (9kg)
 - ✓ Spool gun ready
 - ✓ LCD digital meters
 - ✓ Simple & easy-to-operate
 - ✓ Robust & reliable
 - ✓ Takes 1kg or 5kg spools
 - ✓ Generator friendly (min 7kva)



Part No.	Description
WF-06127	160MST Standard Package
WC-06610	Optional Spool Gun BZL 25 5m
WC-06235	Optional T100 Trolley

ULTRA 175MST⁺

MIG | STICK | TIG



170A output
Max MIG capacity 6mm steel



Easy-to-use Synergic controls



10A plug

Plus

- ✓ H/Duty 250A 3m MIG torch
- ✓ Synergic/auto or manual MIG
- ✓ Programs for steel, fc, ss, alu, bronze
- ✓ Takes 1kg or 5kg spools
- ✓ Generator friendly (min 7kva)
- ✓ Compact & lightweight (9kg)



Part No.	Description
WC-175MST	175MST Standard Package
WC-06231	Optional Stick Lead 4m
WC-00992	Optional TIG Torch #17 4m
WC-06235	Optional T100 Trolley

*Previously Weldforce 175MST

FORCE 180MST MK2

MIG | STICK | TIG



180A output
Max MIG capacity 10mm steel



H/Duty 250A MIG torch



10A plug

Plus

- ✓ Very compact & lightweight (9kg)
- ✓ Spool gun ready
- ✓ LCD digital meters
- ✓ Simple & easy-to-operate
- ✓ Robust drive system
- ✓ Takes 1kg or 5kg spools
- ✓ Generator friendly (min 8kva)
- ✓ Gas or gasless MIG





Part No.	Description
WF-06128	180MST Standard Package
WC-00992	Optional TIG Torch #17 4m
WC-06610	Optional Spool Gun BZL 25 5m
WC-06235	Optional T100 Trolley

FORCE 200MST MK2

MIG | STICK | TIG



-  **200A output**
Max MIG capacity 10mm steel
-  **Takes 5kg AND 15kg spools**
-  **15A plug**

- Plus**
- ✓ Very compact & lightweight (13kg)
 - ✓ H/Duty 250A 4m MIG torch
 - ✓ LCD digital meters
 - ✓ Simple & easy-to-operate
 - ✓ Robust drive system
 - ✓ Spool gun ready
 - ✓ Generator friendly (min 8kva)
 - ✓ Inductance control
 - ✓ Gas or gasless MIG
 - ✓ Large 35-50 output terminals

More Info







Part No.	Description
WF-06129	200MST Standard Package
WC-00992	Optional TIG Torch #17 4m
WC-06610	Optional Spool Gun BZL 25 5m
WC-06235	Optional T100 Trolley

FORCE 205MST

MIG | STICK | TIG



-  **200A output**
Max MIG capacity 10mm steel
-  **PFC** PFC technology = higher duty cycle 200A @ 30%
-  **15A plug**

- Plus**
- ✓ H/Duty 250A 4m MIG torch
 - ✓ Synergic/auto or manual MIG
 - ✓ 20+ MIG programs
 - ✓ Job Save: 20 memory settings
 - ✓ Gear drive wire feed
 - ✓ Takes 1kg or 5kg spools
 - ✓ Spool gun ready
 - ✓ Optional remote TIG torch
 - ✓ Generator friendly (min 8kva)
 - ✓ Compact & lightweight (17kg)

More Info



Part No.	Description
WF-06166	205MST Standard Package
WC-06234	Optional TIG Torch #17 4m Remote
WC-06203	Optional Spool Gun BZL 25 8m
WC-06235	Optional T100 Trolley



ULTRA 210MST⁺

MIG | STICK | TIG



Part No.	Description
WC-210MST	210MST Standard Package
WC-06231	Optional Stick Lead 4m
WC-00992	Optional TIG Torch #17 4m
WC-06235	Optional T100 Trolley

⁺Previously Weldforce 210MST

210A output
Max MIG capacity 10mm steel

Easy-to-use interactive LCD controls

10A plug

Plus

- ✓ Use on 10A or 15A power supply
- ✓ H/Duty 250A 4m MIG torch
- ✓ Synergic/auto or manual MIG
- ✓ Programs for steel, fc, ss, alu, bronze
- ✓ Takes 1kg or 5kg spools
- ✓ Generator friendly (min 7kva)
- ✓ Compact & lightweight (10kg)
- ✓ VRD for safe & compliant stick welding



ULTRA 250MST⁺

MIG | STICK | TIG



Part No.	Description
WC-250MST	250MST Standard Package
WC-06233	Optional Stick Welding Lead
WC-00992	Optional TIG Torch #17 4m
WC-01046	Optional TIG Torch #26 4m
WC-06235	Optional T100 Trolley

⁺Previously Weldforce 250MST

250A output
Max MIG capacity 12mm steel

Easy-to-use Interactive LCD controls

15A plug

ATC technology for outstanding arc control on thin materials

Plus

- ✓ 4m BZL 25 MIG torch
- ✓ Synergic/auto or manual MIG
- ✓ Programs for steel, fc, ss, alu, bronze
- ✓ Takes 5kg or 15kg spools
- ✓ Generator friendly (min 13kva)
- ✓ Compact & lightweight (19kg)
- ✓ VRD for safe & compliant stick welding



FORCE 255MST

MIG | STICK | TIG



- 250A output**
Max MIG capacity 12mm steel
- PFC Technology = higher duty cycle**
250A @ 35%
- Available as compact unit, or with trolley**
- 15A plug**

- Plus**
- ✓ 4m MIG torch
 - ✓ Synergic/auto or manual MIG
 - ✓ 20+ MIG programs
 - ✓ Job Save: 20 memory settings
 - ✓ 4-roll, gear-drive wire feed
 - ✓ Takes 5kg or 15kg spools
 - ✓ Spool gun ready
 - ✓ Optional remote TIG torch
 - ✓ Generator friendly (min 13kva)
 - ✓ Compact & lightweight (26kg)

More Info

Part No.	Description
WF-06167	255MST Standard Package
WC-255MSTK1	255MST Compact Package with Trolley & Toolbox Drawer
WC-06203	Optional Spool Gun BZL 25 8m
WC-06234	Optional TIG Torch #17 4m Remote

FORCE 290MST

MIG | STICK | TIG



- High performance from single-phase power**
- Available as compact unit, or with separate wire feeder**
- 290A @ 55% max output**
- 15A Plug**

- Plus**
- ✓ H/Duty 4m BZL 36 MIG torch
 - ✓ Synergic/auto or manual MIG
 - ✓ Programs for steel, fc, ss, alu, bronze
 - ✓ Job Save: 20 memory settings
 - ✓ Easy-to-use controls
 - ✓ 4-roll, gear-drive wire feed
 - ✓ Takes 5kg or 15kg spools
 - ✓ Spool gun ready
 - ✓ Optional remote TIG torch
 - ✓ Generator friendly (min 15kva)

More Info

Part No.	Description
WC-290MST	290MST Compact Package
WC-290MSTK1	290MST Compact Package with Trolley & Toolbox Drawer
WC-290MSTK3	290MST Separate Wire Feeder Package
WC-290MSTK4	290MST Separate Wire Feeder Package with Toolbox Drawer



FORCE 350MST

MIG | STICK | TIG



Part No.	Description
WC-350MST	350MST Compact Package
WC-350MSTK1	350MST Compact Package with Trolley & Toolbox Drawer
WC-350MSTK3	350MST Separate Wire Feeder Package
WC-350MSTK4	350MST Separate Wire Feeder Package with Toolbox Drawer



350A @ 60% output



Available as compact unit, or with separate wire feeder



32A 415V plug

Plus

- ✓ H/Duty 4m BZL 36 MIG Torch
- ✓ Synergic/auto or manual MIG
- ✓ Programs for steel, fc, ss, alu, bronze
- ✓ Job Save: 20 memory settings
- ✓ Easy-to-use controls
- ✓ 4-roll, gear-drive wire feed
- ✓ Takes 5kg or 15kg spools
- ✓ Spool gun ready
- ✓ Optional remote TIG torch
- ✓ Generator friendly (min 25kva)

More Info



FORCE 395MST PULSE

PULSE MIG | STICK | TIG



Part No.	Description
WC-395MSTK1	395MST Separate Wire Feeder Package
WC-395MSTK2	395MST Separate Wire Feeder Package with Toolbox Drawer



400A @ 60% output



Single & double pulse modes



32A 415V plug



Optional water cooler available

Plus

- ✓ H/Duty 4m BZL 36 MIG torch
- ✓ Wire feeder with 10m cables
- ✓ Programs for steel, fc, ss, alu, bronze
- ✓ Job Save: 20 memory settings
- ✓ Easy-to-use controls
- ✓ 4-roll, gear-drive wire feed
- ✓ Takes 5kg or 15kg spools
- ✓ Spool gun ready
- ✓ Optional remote TIG torch
- ✓ Generator friendly (min 35kva)

More Info



FORCE 135ST

STICK | TIG



- 140A output**
3.2mm max electrode size
- Adjustable hot start & arc force**
- 10A plug**

Plus

- ✓ Extremely compact & lightweight (2.3kg)
- ✓ LCD digital meter
- ✓ Simple & easy-to-operate
- ✓ Optional VRD (activated on request)
- ✓ FREE gloves
- ✓ Generator friendly (min 7kva)
- ✓ High OCV (77V) for very smooth arc & easy striking

More Info

Part No.	Description
WF-06169	135ST Standard Package
WC-00992	Optional TIG Torch #17 4m
4-AR1	Optional Gas Regulator

FORCE 180ST

STICK | TIG



- 180A output**
4.0mm max electrode size
- Adjustable hot start & arc force**
- 15A plug**

Plus

- ✓ LCD digital meter
- ✓ Simple & easy-to-operate
- ✓ Optional VRD (activated on request)
- ✓ 4m leads
- ✓ Generator friendly (min 8kva)
- ✓ Compact & lightweight (4.5kg)

More Info

Part No.	Description
WF-06171	180ST Standard Package
WC-00992	Optional TIG Torch #17 4m
4-AR1	Optional Gas Regulator

FORCE 201T AC/DC PULSE

TIG | STICK



 **200A output**
Max 4-5mm steel/alu

 **Professional TIG welds on alu, steel, stainless & more**

 **15A plug**

Plus

- ✓ 8m #26 flexi-head TIG torch
- ✓ LCD digital controls
- ✓ Simple & easy-to-operate
- ✓ HF or lift-arc ignition
- ✓ Pulse frequency & width controls
- ✓ AC square-wave & balance controls
- ✓ Slope up/down & post/pre gas
- ✓ Optional foot control
- ✓ Generator friendly (min 8kva)
- ✓ Compact & lightweight (8kg)



Part No.	Description
WF-06172	201T Standard Package
WC-06236	Optional Foot Controller
WC-06235	Optional T100 Trolley



**Try The
Weldclass Welder
Selection Guide**

weldclass.com.au/wsg



ULTRA 41PA⁺

PLASMA CUTTER + INBUILT COMPRESSOR



- Inbuilt maintenance-free air compressor = no need for external air supply**
- Ideal for site & field work**
- 40A output
Max 12mm steel
(18mm severance)**

Plus

- ✓ Simple & easy-to-operate
- ✓ Clean cut 12mm steel
- ✓ Clean cut 12mm stainless
- ✓ Clean cut 10mm aluminium
- ✓ Severance cut 18mm steel
- ✓ Rugged roll-frame design
- ✓ Generator friendly (min 8kva)
- ✓ Compact & lightweight (16Kg)
- ✓ Warning system prevents torch damage



Part No.	Description
WC-41PA	41PA Standard Package
WC-06235	Optional T100 Trolley

*Previously Cutforce 41PA

FORCE 45P

PLASMA CUTTER



- 40A output
Max 20mm steel
(25mm severance)**
- PFC Technology = higher duty cycle 40A @ 45%**
- Advanced LCD controls**
- 15A plug**

Plus

- ✓ High quality 6m plasma torch
- ✓ Clean cut 20mm steel
- ✓ Clean cut 18mm stainless
- ✓ Clean cut 14mm aluminium
- ✓ Severance cut 25mm steel
- ✓ Advanced LCD controls
- ✓ Generator friendly (min 8kva)
- ✓ Perforated / mesh cutting mode
- ✓ Compact & lightweight (8Kg)
- ✓ Warning system prevents torch damage







Part No.	Description
CF-06176	45P Standard Package
WC-06255	Optional Z-20 Hi-Performance Air Filter
WC-06235	Optional T100 Trolley
WC-01658	Optional Parts Kit with Roller Guide

DRIVE ROLLERS

Suit Weldclass MIG Machines

May also suit other machine brands & models, check drive roller dimensions.

Shape	O.D. (mm)	I.D. (mm)	Width (mm)	Suits Weldclass Machines	Groove Shape	Wire Type	Wire Sizes (mm)	Part No.
	25	7sq	7.5	160MST, 132MST, 131GL, 141GL	V	Steel / Solid	0.6/0.8	WC-06217
					Knurled	Gasless / Flux-Core	0.8/0.9	WC-06219
						V	Steel / Solid	0.6/0.8-0.9
	30	7sq	7	155M, 175MST, 210MST	Knurled	Gasless / Flux-Core	0.8-0.9/1.2	WC-06425
					Mixed	Aluminium U0.9-1.0 / Steel V1.0		WC-06426
		30	10	10	180MST, 200MST	V	Steel / Solid	0.6/0.8
Knurled						Gasless / Flux-Core	0.8/0.9	WC-06221
						Gasless / Flux-Core	0.8/0.9	WC-06222
						Gasless / Flux-Core	0.9/1.2	WC-06228
U	Aluminium	1.0/1.2	WC-06227					
	30	22	10	205MST	V	Steel / Solid	0.6/0.8	WC-06186
					Knurled	Steel / Solid	0.8/0.9	WC-06187
						Gasless / Flux-Core	0.8/0.9	WC-06188
						Gasless / Flux-Core	0.9/1.2	WC-06189
						Aluminium	1.0/1.2	WC-06190
	30	10	18	220MP, 250MST	V	Steel / Solid	0.6/0.8	WC-06438
					Knurled	Steel / Solid	0.8/0.9	WC-06556
						Gasless / Flux-Core	1.0/1.2	WC-06439
						Gasless / Flux-Core	0.9/1.2	WC-06443
					U	Aluminium	0.9/1.0	WC-06440
						Aluminium	1.0/1.2	WC-06441
	30	10	12	255MST, 290MST, 350MST, 395MST, SWF106, SWF114	V	Steel / Solid	0.6/0.8	WC-06191
					Knurled	Steel / Solid	0.8/1.2	WC-06192
						Gasless / Flux-Core	0.8/0.9	WC-06193
						Gasless / Flux-Core	0.9/1.2	WC-06194
						Gasless / Flux-Core	1.2/1.6	WC-06293
					U	Aluminium	1.0/1.2	WC-06195

PLATINUM Z-20 AIR FILTER

For Plasma Cutting Machines

- ✓ Increases Plasma torch parts life & reduces consumable costs
- ✓ Improves cutting performance
- ✓ Self-draining - engineered for low maintenance, "set and forget"
- ✓ Long-life filter cartridge (typical service life of up to 6 months)
- ✓ High-performance filtration of water/moisture, dirt and oil particles down to 1-micron

PART NO.	DESCRIPTION
WC-06255	Complete Filter Unit - includes Nitto coupler, Nitto plug, 1/4" nipple/joiner
WC-06255	Replacement Filter Element





PROMAX T100

Welder Trolley

Robust Construction

Double Gas Bottle Chain



Large Top Tray
L700 x W275mm
Suits most machines
up to 250 amps

Outrigger Front Wheels
For added stability



More Info

Part No.	Description
WC-06235	Welding Trolley - Promax T100

TX-180

Plate Cutter

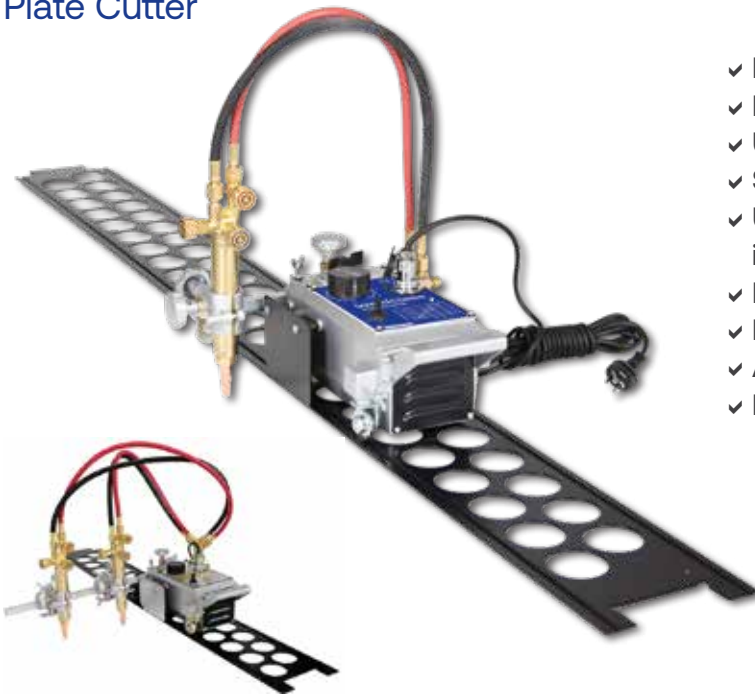

- ✓ Lightweight and portable
- ✓ Robust design
- ✓ Use with Oxy/Acetylene or Oxy/LPG
- ✓ Straight or bevel cutting of steel plate
- ✓ Uses common track design - track is interchangeable with other machines
- ✓ Horizontal and vertical torch adjustment
- ✓ Heat deflector
- ✓ Adjustable speed
- ✓ Forward and reverse



Part No.	Description
5-TX180/1K	TX-180 Plate Cutter Package - with Single Torch & 1.8m Track
5-TX180TTK	TX-180 2 Torch Upgrade Kit (Converts 1-Torch Machine to 2-Torch)
5-SX300T	Track 1.8m suits TX-180 & Various Other Models

More Info

TX-21Q

Pipe Cutter

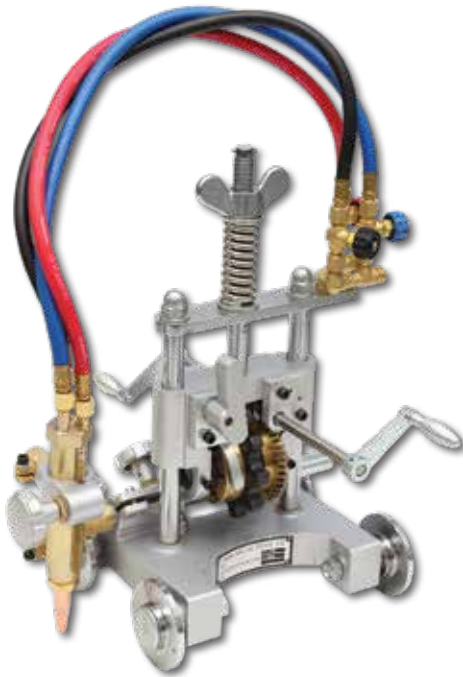
7 YEAR
WARRANTY
OFFER

- ✓ Unique Quick-Clutch feature for fast positioning of machine
- ✓ Lightweight and portable
- ✓ Robust design
- ✓ Ideal for cutting steel pipes 100mm or larger
- ✓ Use with Oxy/Acetylene or Oxy/LPG
- ✓ Horizontal and vertical torch adjustment
- ✓ Straight or bevel cutting
- ✓ Supplied with additional wheel flanges to increase chassis clearance for cutting smaller pipes



Part No.	Description
5-TX21Q	TX-21Q Pipe Cutter w/Quick-Clutch & 2.4m Chain
5-TX21CHAIN	Chain 2.4m

More Info 

TX-55

Portable Profile Cutter

7 YEAR
WARRANTY
OFFER

- ✓ Template-tracing profile flame-cutting machine
- ✓ Robust design
- ✓ Use with Oxy/Acetylene or Oxy/LPG
- ✓ Portable - weighs only 55kg



Part No.	Description
WC-05310	TX-55 Portable Profile Cutter

More Info 

ALLCLEAR MA100

Mobile Fume Extractor



Manual Cleaning



Cleanable, Re-usable Filter
= Lower Operating Costs



~230V 10A plug

- ✓ For welding, grinding, plasma & gouging fumes
- ✓ Single 3m arm
- ✓ Manual filter cleaning (access via filter cleaning door, clean with compressed air nozzle)
- ✓ Compact and mobile

Part No.	Description
91100MA1	ALLCLEAR MA100 1ph/230V with Single 3m Arm
91990116	Replacement main cartridge filter standard F9
91990118	Optional HEPA (high efficiency) H13 main cartridge filter
91990120	Optional Carbon filter for odour reduction



ALLCLEAR MA300 AUTO

Mobile Fume Extractor



Auto-Cleaning



Cleanable, Re-usable Filter
= Lower Operating Costs



~230V 10A plug

- ✓ For welding, grinding, plasma & gouging fumes
- ✓ Single 3m arm
- ✓ Automatic filter cleaning (requires unit to be connected to compressed air supply)
- ✓ With: working hour counter, filter fullness indicator, malfunction warning, special dust collection bin
- ✓ Compact and mobile

Part No.	Description
91300AMA1	ALLCLEAR MA300 AUTO 1ph/230V with Single 3m Arm
91990116	Replacement main cartridge filter standard F9
91990118	Optional HEPA (high efficiency) H13 main cartridge filter
91990122	Optional Carbon filter for odour reduction



ALLCLEAR MA350

Mobile Fume Extractor



3 YEAR
WARRANTY
OFFER



Manual Cleaning



Cleanable, Re-usable Filter
= Lower Operating Costs



415V plug

- ✓ For welding, grinding, plasma & gouging fumes
- ✓ Twin 3m arms for extended reach/coverage
- ✓ Manual filter cleaning (access via filter cleaning door, clean with compressed air nozzle)
- ✓ With: working hour counter, filter fullness indicator, malfunction warning, special dust collection bin
- ✓ Compact and mobile

Part No.	Description
91350MA3	ALLCLEAR MA350 3ph/415V with Twin 3m Arms
91990116	Replacement main cartridge filter standard F9
91990118	Optional HEPA (high efficiency) H13 main cartridge filter
91990122	Optional Carbon filter for odour reduction

More Info 



ALLCLEAR MA350 AUTO

Mobile Fume Extractor



3 YEAR
WARRANTY
OFFER



Auto-Cleaning



Cleanable, Re-usable Filter
= Lower Operating Costs



415V plug

- ✓ For welding, grinding, plasma & gouging fumes
- ✓ Twin 3m arms for extended reach/coverage
- ✓ Automatic filter cleaning (requires unit to be connected to compressed air supply)
- ✓ With: working hour counter, filter fullness indicator, malfunction warning, special dust collection bin
- ✓ Compact and mobile

Part No.	Description
91350AMA3	ALLCLEAR MA350 AUTO 3ph/415V with Twin 3m Arms
91990116	Replacement main cartridge filter standard F9
91990118	Optional HEPA (high efficiency) H13 main cartridge filter
91990122	Optional Carbon filter for odour reduction

More Info 



ALLCLEAR FA25

Welding Fume Extraction Fan

- ✓ Wall-mounted, for minimal intrusion in work spaces
- ✓ Commonly used with ducted systems, where fumes are ducted externally and/or to large central extraction/filter units
- ✓ Operates on ~230V 10A single phase power
- ✓ Available with 3m or 4m suction arms (sold separately to the fan)
- ✓ Powerful 1.1kw fan, with max 2,500m³ air flow



Part No.	Description
91025FA1	Fan/Motor with Wall-Mounted Bracket & Switch / Control Box
91005003	Arm Assembly 3m
91005004	Arm Assembly 4m

Note: This unit is an extraction fan only and does not include a filter. Suitable 'as-is' for mild / non-toxic airborne contaminants. Can be used for welding and grinding fumes, if used together with a suitable filtration system.

More Info  

ALLCLEAR TA100

Fume Extraction Welding & Grinding Table

- ✓ Down-draft table with inbuilt filter
- ✓ For welding & light grinding
- ✓ Operates on ~230V 10A single phase power
- ✓ Compact and mobile
- ✓ Ideal for education and training applications
- ✓ Powerful 1kw fan, with max 3,000m³ air flow



Part No.	Description
91100TA1	ALLCLEAR TA100 Table
91990117	Replacement Box Filter F9

More Info  

SAFETY & PROTECTION



A HELMET FOR EVERY FABRICATOR







Model	Promax 150	Promax 180	Promax 200	Promax 350	Promax 500	Promax 600	Promax 650	Promax 680
View Size	89 x 39mm	96 x 39mm	96 x 39mm	100 x 53mm	98 x 87mm	108 x 74mm	108 x 82mm	116 x 82mm
View Area	35cm ²	37cm ²	37cm ²	53cm ²	80cm ²	80cm ²	89cm ²	95cm ²
Enhanced Colour Recognition				✓				
Optical Rating	1/1/1/2	1/1/1/2	1/1/1/2	1/1/1/1	V2 (1/1/1/2)	V1 (1/1/1/1)		
Magnification Lens Holder				✓				
MIG & Stick				✓				
TIG		✗		✓30A			✓>5A	
Grind Mode	✗			✓				✓Internal & External
Plasma Cutting, Arc Gouging	✗	✗					✓	
Oxy Cutting / Brazing			✗				✓	✓With Shade Lock
Shade Adjustment	9-13	9-13		5-8/9-13		4-8/9-14 Plus Shade Lock		4-8/9-14 Auto or Manual, Plus Shade Lock
Sensitivity Adjustment				✓				✓Auto or Manual
Delay Time Adjustment		✓				✓Plus Gradient Mode		✓Auto or Manual, Plus Gradient Mode
Sensors	2			4				4 Arc Sensors + 1 Intensity Sensor
Memory		✗					✓	✓10 memory Settings
Powered Respirator (PAPR)					✗			
Warranty* *On Auto-Darkening Lens	7 Year Warranty Offer*							
Weight	460g	460g	460g	480g	560g	560g	580g	620g

PROMAX 150

Welding Helmet

7 YEAR WARRANTY OFFER

-  Shade 9-13, sensitivity & delay adjustments
-  Ultra-crisp optics
-  Magnification lens holder
-  For MIG & stick

Plus

- ✓ External shade adjustment
- ✓ 35cm² view area
- ✓ Easy cover lens replacement
- ✓ Enhanced colour recognition

Black WC-05163



More Info 







weldclass.com.au/pm150

PROMAX 180

Welding Helmet

7 YEAR WARRANTY OFFER

-  Shade 9-13, sensitivity & delay adjustments
-  Ultra-crisp optics
-  Magnification lens holder
-  For MIG & stick

Plus

- ✓ 37cm² view area
- ✓ Easy cover lens replacement
- ✓ Enhanced colour recognition

Black WC-05164



More Info 



weldclass.com.au/pm180

PROMAX 200

Welding Helmet

7 YEAR
WARRANTY
OFFER*



Shade 9-13, sensitivity,
delay & grind functions



Ultra-crisp optics



Magnification lens
holder



For MIG, stick,
grinding

Plus

- ✓ 37cm² view area
- ✓ Easy cover lens replacement
- ✓ Enhanced colour recognition

Slate WC-05311



More
Info



weldclass.com.au/pm200

PROMAX 350

Welding Helmet

7 YEAR
WARRANTY
OFFER*



4 sensors & large
53cm² view



Shade 5-8/9-13,
sensitivity, delay
& grind functions



Ultra-crisp optics



For MIG, stick, TIG (≥30A),
grinding, plasma

Plus

- ✓ Replaceable battery
- ✓ Magnification lens holder
- ✓ High-impact rated to AS/NZS 1337.1
- ✓ Easy cover lens replacement
- ✓ Enhanced colour recognition

Blue WC-05313

Aussie WC-05315



More
Info



weldclass.com.au/pm350

PROMAX 500

Welding Helmet



4 sensors & super-size
85cm² view



Shade 5-8/9-13,
sensitivity, delay
& grind functions



Ultra-crisp optics



For MIG, stick, TIG (≥5A),
grinding, plasma

Plus

- ✓ Replaceable battery
- ✓ Magnification lens holder
- ✓ High-impact rated to AS/NZS 1337:1
- ✓ Easy cover lens replacement
- ✓ Enhanced colour recognition

Black Stealth WC-05317

Weldwolf WC-05318

Revhead WC-05319



7 YEAR
WARRANTY
OFFER*



ENHANCED
COLOUR
RECOGNITION



More
Info



weldclass.com.au/pm500

PROMAX 600

Welding Helmet



4 sensors & extra-large
80cm² view



Shade 4-8/9-13, sensitivity,
delay, grind, cut, memory,
gradient functions



Ultra-crisp optics



For MIG, stick, TIG (≥5A),
grinding, plasma, oxy,
gouging

Plus

- ✓ Replaceable batteries
- ✓ Magnification lens holder
- ✓ High-impact rated to AS/NZS 1337:1
- ✓ Enhanced colour recognition
- ✓ Landscape lens format for wider field of view
- ✓ 10 memory settings

Armour WC-05340



7 YEAR
WARRANTY
OFFER*



ENHANCED
COLOUR
RECOGNITION



More
Info



weldclass.com.au/pm600

PROMAX 650

Welding Helmet

7 YEAR
WARRANTY
OFFER*



4 sensors & extra-large
89cm² view with ultra-crisp
V1-rated optics



Shade 4-8/9-13, sensitivity,
delay, grind, cut, memory,
gradient functions



External grind mode button



For MIG, stick, TIG (≥5A),
grinding, plasma, oxy,
gouging

Plus

- ✓ Replaceable batteries
- ✓ Magnification lens holder
- ✓ High-impact rated to AS/NZS 1337.1
- ✓ Enhanced colour recognition
- ✓ Landscape lens format for wider field of view
- ✓ 10 memory settings

Matte Black WC-05343



More
Info



weldclass.com.au/pm650

PROMAX 680

Digital Welding Helmet

7 YEAR
WARRANTY
OFFER*



Super-size 95cm²
view with 1/1/1/1 (V1)
rated optics



Advanced digital
controls + illuminated
LCD screen



External controls for
grind, shade & more



Auto or manual
shade, sensitivity
& delay control

Plus

- ✓ Dual shade 4-8 / 9-14
- ✓ Weld, Grind, Cut, Tack modes
- ✓ Magnification lens holder
- ✓ High impact rated to AS/NZS 1337.1
- ✓ 5 sensors (4 arc + 1 intensity)
- ✓ TIG Optimised (>5 Amps)
- ✓ 10 Memory settings

Matte Blue WC-05344

Blue Retro WC-05345



More
Info



weldclass.com.au/pm680

**New Product
Coming Soon**

**New Product
Coming Soon**

PROMAX 100

Electronic Welding Lens



Fits standard flip-front helmets

11

Shade 11



Suitable for MIG & Stick

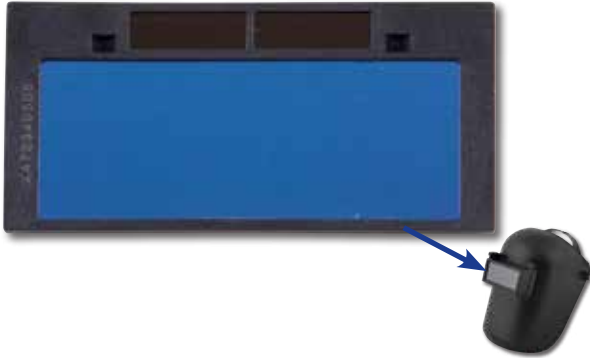

Part No.	Description
WC-04094	Shade 11 - 108 x 51mm

HELMET

Flip Front

- Complies with AS1337 medium impact
- Takes standard 108x51mm lenses



Part No.	Description
7-FFH	Flip Front Helmet

**New Product
Coming Soon**

SPARE PARTS

For Weldclass Auto-Darkening Helmets

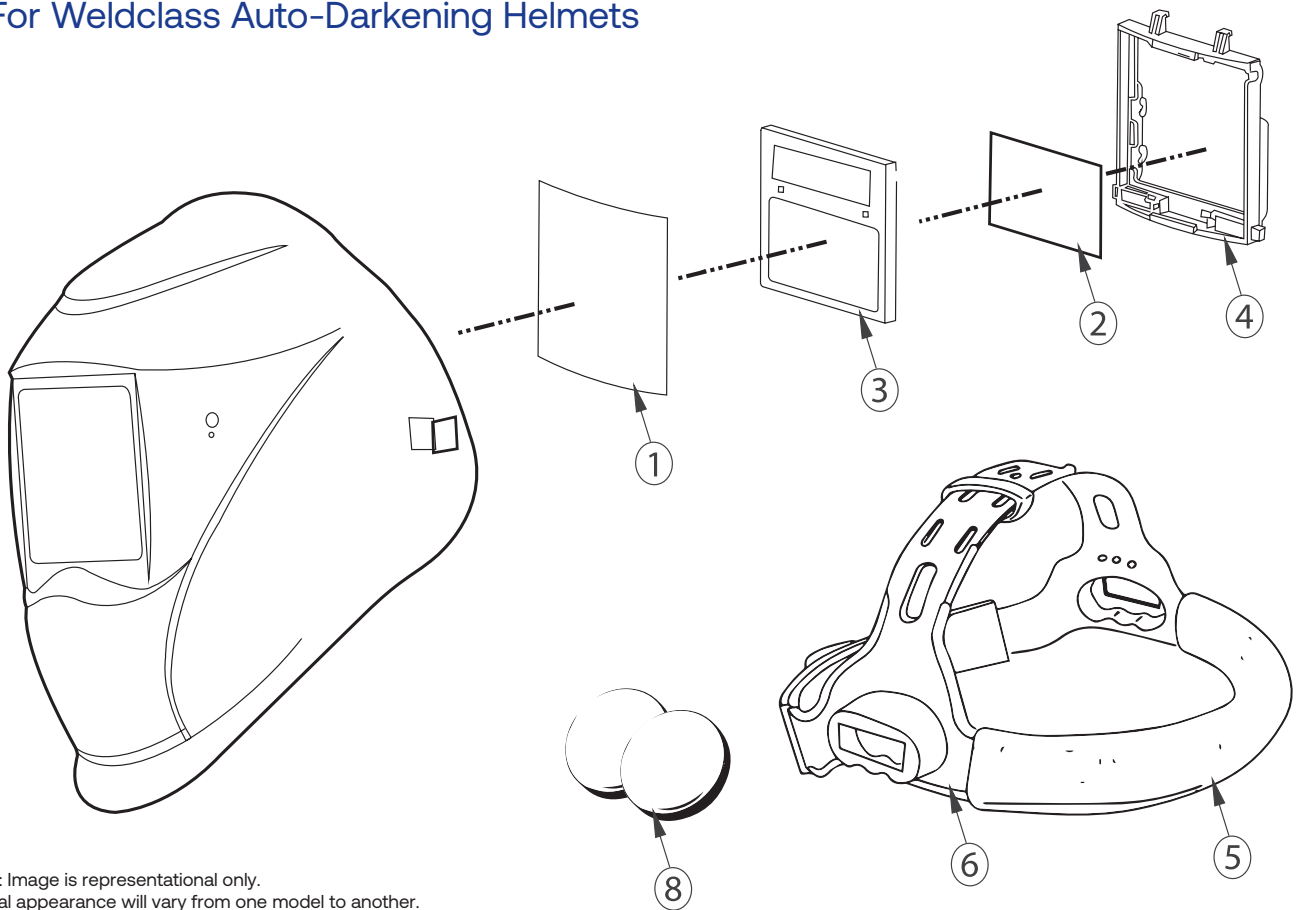

Note: Image is representational only.
Actual appearance will vary from one model to another.

Ref	Description	Suits Helmet Models	Part No.	Unit
1	Cover Lens Outer	Promax 150, 180, 200, 350	WC-05323	Pk 10
		Promax 500	WC-05324	Pk 10
		Promax 600, 650, 680	WC-05352	Each
		Promax 850R Outer Lens	WC-06707	Pk 5
		Promax 850R Grinding Visor	WC-06709	Pk 5
2	Cover Lens Inner	Promax 180, 200	WC-05320	Pk 5
		Promax 350	WC-05321	Pk 5
		Promax 500	WC-05322	Pk 5
		Promax 600, 650	WC-05350	Pk 5
		Promax 680, 680R, 850R	WC-05357	Pk 5
1&2	Cover Lens Kit (2 Outer + 1 Inner)	Promax 150	WC-05333	Kit
		Promax 180, 200	WC-05334	Kit
		Promax 350	WC-05335	Kit
		Promax 500	WC-05336	Kit
		Promax 600, 650, 680	WC-05351	Kit
3	Auto-Darkening Lens Cassette	Promax 200 (also suits 180)	WC-05327	Each
		Promax 350	WC-05328	Each
		Promax 500	WC-05329	Each
		Promax 600	WC-05346	Each
		Promax 650	WC-05349	Each
		Promax 680	WC-05354	Each
		Promax 850R	WC-06698	Each
4	Lens Retainer Frame & Latch	Promax 180, 200, 350	WC-05330	Kit
		Promax 500	WC-05331	Kit
5	Sweatband	All Promax Models	WC-01630	Pk 5
6	Headgear Assembly	Promax 150, 180, 200, 350, 500	WC-05325	Each
		Promax 600, 650, 680	WC-05353	Each
		Promax 680R, 850R	WC-06694	Each
8	Battery 'CR2032'	Promax 350	Available from most battery retailers	
	Battery 'CR2450'	Promax 500, 600, 650, 680, 850R		

MAGNIFICATION LENSES

108 x 51mm

- Size 108 x 51mm
- Suits most standard flip-front helmets & auto helmets with mag lens holder
- Improves clarity of vision



Part No.	Description
P7-ML15	1.5x Diopter
P7-ML20	2.0x Diopter
P7-ML25	2.5x Diopter

SHADE LENSES

108 x 51mm

- Size 108 x 51mm - suits most standard flip-front helmets



Part No.	Description	Pack Qty	Carton Qty
7-SL9	Shade 9	10	100
7-SL10	Shade 10	10	100
7-SL11	Shade 11	10	100
7-SL12	Shade 12	10	100

CLEAR LENSES

For Standard Flip Front Helmets

- Size 108 x 51mm - suits most standard flip-front helmets

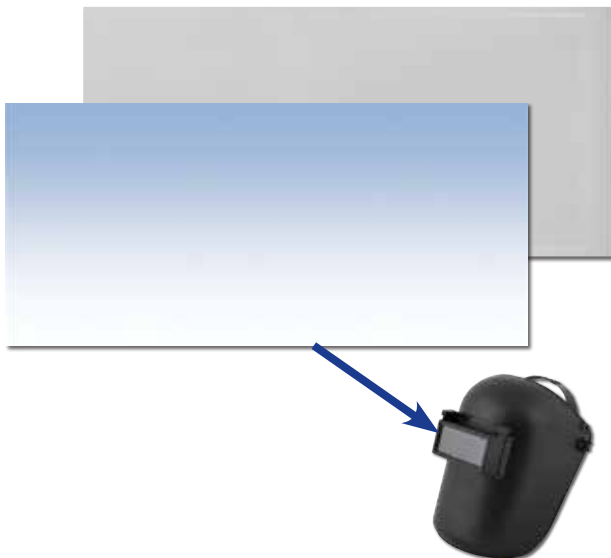

Part No.	Type	Unit
WC-01636	CR39	Each (100 per box)
P7-CL39/5	Spatter-resistant	Carded Pk 5
7-CLPC	Polycarbonate impact-resistant	Each (100 per box)

PROMAX SB2

Universal Sweatbands



Absorbent towel with hook & loop fastening



Universal, fits most helmets



Long-life, washable, re-usable



Part No.	Description
WC-01630	Promax SB2 Sweatbands Pk5

CLEAR COVER LENS RANGE

For Auto-Darkening Welding Helmets

- ✓ Find the right lens for your helmet fast!
- ✓ Wide range to suit many common helmet brands & models
- ✓ Online tool, simply enter helmet brand & model to view suitable/available lenses



weldclass.com.au/ClearLens

GOGGLES & SPECS

For Oxy & Plasma

- Shade 5 lenses
- Suitable for Oxy and Plasma work



Part No.	Description	Ref
P7-OGFF	Goggle Standard	A
P7-OGFFL	Goggle 108 x 51mm Lens	B
7-MS5	Shade 5 Specs	C

SAFETY SPECS

Ace

- Low cost and stylish eye protection
- Close fitting wrap around design
- Full UV protection against sun glare
- Certified to AS/NZS 1337.1 - Medium impact



Part No.	Description
7-ACC	Clear
7-ACS	Smoke
7-ACA	Amber (Indoor / Light Enhancing)

FACE SHIELDS

- AS1337.1 High-Impact rated
- Available in Clear or Shade 5 for oxy/plasma



Part No.	Description
7-FSC	Complete Face shield - Clear
7-FCV	Replacement Visor Only - Clear
7-FS5	Complete Face shield - Shade 5
7-F5V	Replacement Visor Only - Shade 5

WELDING CURTAINS



- Protect personnel from indirect welding flash
- Allows natural light into work areas
- Fire retardant & conforms to EN ISO 25980 international standard

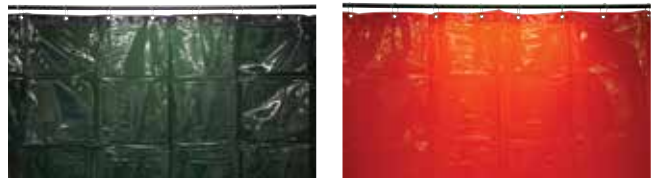

Part No.	Description
7-1818G	1.8 x 1.8m Green
7-1818R	1.8 x 1.8m Red
7-1820G	1.8 x 2.0m Green
7-1820R	1.8 x 2.0m Red
7-1827G	1.8 x 2.7m Green
7-1827R	1.8 x 2.7m Red
7-1834G	1.8 x 3.4m Green
7-1834R	1.8 x 3.4m Red
7-1855G	1.8 x 5.5m Green

More
Info



weldclass.com.au/curtains

WELDING CURTAIN FRAMES & KITS

Standard

- Coated steel pipe frame
- Spring pin joints for fast assembly
- Includes castor wheels
- Multiple frames can be joined together (connectors included)

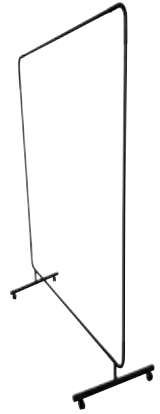

More
Info



weldclass.com.au/wcf1

Part No.	Description
WC-03238K	Frame + Curtain Kit 1.8x1.8m Red
WC-03239K	Frame + Curtain Kit 1.8x1.8m Green
WC-03240K	Frame + Curtain Kit 1.8x2.0m Red
WC-03241K	Frame + Curtain Kit 1.8x2.0m Green
WC-06469	Frame Only - Dual Length Suits 1.8x1.8m and 1.8x2.0m Curtains

WELDING CURTAIN FRAMES & KITS

Heavy Duty

- Heavy-duty RHS coated steel frame
- Welded corner brackets
- Lockable castor wheels
- Multiple frames can be joined together (bolts provided)



More
Info



weldclass.com.au/wcf2

Part No.	Description
WC-03235K	Frame + Curtain Kit H/Duty 1.8x2.0m Red
WC-03236K	Frame + Curtain Kit H/Duty 1.8x2.0m Green
7-WCF1820	Frame Only H/Duty - Suit 1.8 x 2.0m Curtain

PROMAX EP5

Disposable Earplugs

- Popular taper fit, soft foam style earplugs for general use
- Tested and conform to AS/NZS1270:2002 for Class 5 protection
- Each pair is hygienically packed in clear plastic bag



Part No.	Description	Unit
WC-05377	Un-corded	Box 200pr

EARMUFFS



Part No.	Description	Ref
P7-EMC4	Earmuff 24dB Class 4	A
P7-EM30	Earmuff 30dB Foldable	B

PROMAX KR

Rigger Gloves

- Premium A-grade cow grain leather
- Kevlar® stitched for long life



Part No.	Size	Pack Qty	Carton Qty
8-WRM	M	12 pr	60 pr
8-WRL	L	12 pr	60 pr
8-WRXL	XL	12 pr	60 pr
8-WR2XL	2XL	12 pr	60 pr

PROMAX WG14

Welding Gloves

- Crafted for comfortable fit
- Split cowhide leather
- Fully welted seams
- Fully lined



Part No.	Description	Pack Qty	Carton Qty
WC-01805	Standard Pairs	12 pr	48 pr

PROMAX WG16

Welding Gloves

- Crafted for excellent fit: Try a pair to experience the difference!
- Top Quality: Premium cowhide leather, reinforced, sewn with heat-resistant Kevlar® thread
- Available in Left-Hand only, for use where only lefts are used, or where lefts wear at a faster rate than rights

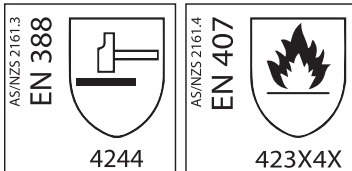

“lasts twice as long under heavy use as competitors brands”

- James, QLD

Part No.	Description	Pack Qty	Carton Qty
WC-01775	Standard Pairs	12 pr	48 pr
WC-01777	Left-Hand Pairs	12 pr	48 pr

Super comfortable
⇌ super tough!



PROMAX BLUE WG16XC

Welding Gloves

- Extended Cuff: Provides full arm protection - total glove length 680mm
- Top Quality: Premium cowhide leather, reinforced palm, sewn with heat-resistant Kevlar® thread
- In hot environments where excess clothing can be a health risk, Platinum XC gloves are sometimes used in place of a full jacket, as they offer full arm protection
- Available in Left-Hand only, for use where only lefts are used, or where lefts wear at a faster rate than rights

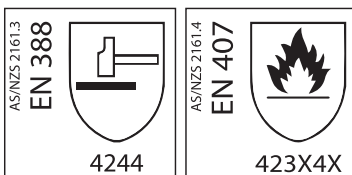

“Been welding for about 10 years, one of the best gloves out there”

- Sam, SA

Part No.	Description	Pack Qty	Carton Qty
WC-01774	Standard Pairs	6 pr	24 pr
WC-01778	Left-Hand Pairs	6 pr	24 pr

Extra-long for full arm protection!



PLATINUM TG-21

TIG Welding Gloves

- Top selling TIG Glove: Try a pair to experience the difference!
- Specially selected leather and carefully crafted for maximum comfort and sensitivity
- The Best of Both: Excellent dexterity/feel and good heat-resistance/long life
- Sewn with heat-resistant Kevlar® thread = Resistant to seam failure

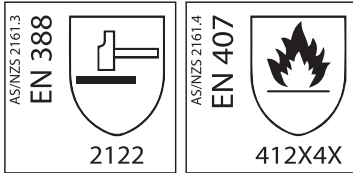

“Very comfortable and lasts for ages, great quality”

- Edwin, QLD



Part No.	Pack Qty	Carton Qty
WC-04676	12 pr	48 pr



PROMAX GLOVE SAVERS

- Reduces "Hot Hand" - Aluminized/reflective Kevlar® back reflects heat away from welding glove
- Increases glove life, provides extra protection of palm, upper & thumb
- Slip over any welding glove
- Sewn with heat-resistant Kevlar® thread



Part No.	Description
WC-01764	Left Hand
WC-01765	Right Hand

WELDING APPAREL RANGE

World Class Comfort & Durability



Top quality craftsmanship



Premium materials



Superior comfort & durability



7 year warranty offer*



*Offered on jackets & some other selected apparel items where advertised.

PROMAX SPB

Leather Spats



- Protect your boots and feet from spatter, sparks, etc
- Buckle closure
- Premium cowhide leather
- Sewn with Kevlar® thread
- Side stiffeners
- Height 310mm



Part No.	Description	Unit
WC-01815	Height 310mm	Pair

PROMAX SPV

Leather Spats



- Protect your boots and feet from spatter, sparks, etc
- Hook & Loop closure
- Premium cowhide leather
- Sewn with Kevlar® thread
- Side stiffeners
- Height 340mm



Part No.	Description	Unit
WC-01816	Height 340mm	Pair

PROMAX HB/HV

FR Hoods



PROMAX HV



Comfortable Protection

Draw String Face Closure

Hook & Loop Opening

Wide Apron

Kevlar® Stitched

More Info



weldclass.com.au/HoodB

Part No.	Description
WC-01795	Promax HB Blue
WC-03772	Promax HV Hi-Vis Orange

PROMAX HS

FR Hood for Welding Helmet



Blocks Distracting Light & Reflections

Spatter, Spark & Sun Protection

Kevlar® Stitched

Light, Comfortable, Cool

Easily Attach to Any Welding Helmet

Supplied with self-stick hook & loop



More Info



weldclass.com.au/Hoods

Part No.	Description
WC-05456	PROMAX HS Hood with self-stick Hook & Loop

PROMAX BLUE

Leather Apron



Adjustable Webbing Straps



Premium Leather:
Top quality split cowhide leather

Riveted Stress Points & Double-Stitched with Kevlar®: Longer garment life in tough conditions

Does Not Shed Fibres like standard grey/chrome leather

Chest to Knee Protection:
900mm long



Utility Pocket:
For tools, rulers, markers etc

Part No.	Description
WC-01753	Leather Apron 900 x 600mm

PROMAX SL4

Leather/FR Sleeves



Comfortable & Firm Fit

Flexible and Light FR Upper



Leather Forearm

Kevlar® Stitched

More Info



weldclass.com.au/SL4

Part No.	Description	Unit
WC-05375	Leather/FR Sleeves	Pair

PROMAX BL7

Leather Welding Jackets



Durable

Premium cowhide, sewn with Kevlar®

Lighter & Cooler

Special design, up to 40% lighter than other full-leather jackets

Offset Opening

For improved wear & comfort

Adjustable Cuffs

Extended Back

Protects when bending & kneeling



More Info



weldclass.com.au/BL7

Part No.	Size
WC-01782	M
WC-01781	L
WC-01783	XL
WC-01784	2XL

PROMAX BF3

FR/Leather Welding Jackets



Pen / Scribe Pockets

On both sleeves

Comfortable

Fire-retardant cotton body = lighter and cooler than full leather

Pockets

Pen pockets on sleeves, plus double front pockets

Leather Sleeves

Premium cowhide for heavy-duty spatter & spark protection

Kevlar® Stitched

Durable, heat resistant seams

Extended Back

Protects when bending & kneeling



Wide Hook & Loop Strip

For firm closure (no studs to tear off)

More Info



weldclass.com.au/BF3

Part No.	Size
WC-04653	M
WC-04658	L
WC-04655	XL
WC-04656	2XL
WC-04651	3XL

PROMAX BLUE FLAME

FR Welding Jackets

Eye-Catching
Flame Graphics



Light & Cool
FR cotton for medium duty protection, lighter and cooler than leather

Pockets
Pen pockets on sleeves, plus internal front pockets

Kevlar® Stitched
Durable, heat resistant seams

Adjustable Cuffs



Pen / Scribe Pocket
Handy spot for markers, scribes, small rules, etc



More Info



weldclass.com.au/BlueFlame

Part No.	Size
WC-01797	M
WC-01798	L
WC-01799	XL
WC-01800	2XL

PROMAX HV2

FR/Leather Hi-Vis Welding Jackets

Harness Compatible
Rear opening flap allows use with safety harness, if required



Safe & Comfortable
Hi-Vis FR cotton body, with reflective tape, lighter and cooler than full leather

Pockets
Pen pockets on sleeves, plus internal front pocket

Leather Sleeves
Premium cowhide for heavy-duty spatter & spark protection



Extended Back
Protects when bending & kneeling

More Info



weldclass.com.au/HV2

Part No.	Size
WC-04762	M
WC-04763	L
WC-04764	XL
WC-04765	2XL
WC-04766	3XL
WC-04767	4XL

PROMAX HV5

FR Welding Jackets



Light & Cool
FR cotton for medium duty protection, lighter and cooler than leather

Pockets
Pen pocket on sleeve

Kevlar® Stitched
Durable, heat resistant seams



Internal Pocket

More Info



weldclass.com.au/HV5

Part No.	Size
WC-05261	M
WC-05262	L
WC-05263	XL
WC-05264	2XL

LEATHER CABLE COVERS

Suit Torch Cables

- Extends the life of torch cables = Reduced replacement/repair costs & down-time
- Velcro style fastening for quick fitting
- Premium blue heavy duty cowhide leather, and heat-resistant Kevlar® thread
- Can be cut to length if required
- Ideal for MIG, TIG & Plasma torch cables



Part No.	Description
8-CC4	4m x 150mm - Suit 3-4m MIG/TIG Torches
8-CC7	7.5m x 150mm - Suit 7-8m TIG/Plasma Torches

LEATHER CABLE COVERS

Suit Wire-Feeder Cables

- Extends the life of torch cables = Reduced replacement/repair costs & down-time
- Velcro style fastening for quick fitting
- Premium blue heavy duty cowhide leather, and heat-resistant Kevlar® thread
- Can be cut to length if required
- Ideal for MIG welder wire-feeder cables



Part No.	Description
8-CC8	8m x 200mm - Suit 8m Wire-Feeder Cables
8-CC10	10m x 200mm - Suit 10m Wire-Feeder Cables

WELDING BLANKET SELECTION GUIDE

	PROMAX LEATHER	PROMAX WB550	PROMAX WB1000	PROMAX WB1100	PROMAX WB1250+
Key Features	<ul style="list-style-type: none"> General purpose Economical Durable cowhide leather Sewn with kevlar thread High density, resists spark penetration Non-irritant 	<ul style="list-style-type: none"> General purpose Economical Glass fibre, heat-treated to reduce fraying & irritation Heavier weight for durability 	<ul style="list-style-type: none"> 'Medium duty' Glass fibre, treated for higher temperature resistance & retention Strong, heat & abrasion resistant Heavier weight for durability 	<ul style="list-style-type: none"> 'Heavy duty' Silica glass fabric for high temperature tolerance Protects against heavier sparks, spatter, slag, etc Soft & flexible fabric Heavier weight for durability 	<ul style="list-style-type: none"> 'Heavy duty' High-tech proprietary coating Lightweight, yet offers high temperature protection Non-irritant, does not shed dust or fibres Provides new levels of performance, safety & ergonomics
Sizes / Part No's	1.0x2.0m 8-LWB1 1.8x1.8m* 8-LWB1818 2.0x2.0m* 8-LWB2 3.0x3.0m* 8-LWB3	1.0x1.8m 8-WB550/1018 1.8x2.0m* 8-WB550/1820 2.0x3.0m 8-WB550/2030 1.0x2.5m Roll WC-06688	0.9x1.8m WC-06688 1.8x1.8m WC-06689	0.9x1.8m 8-WBSG1/0918 1.8x2.0m* 8-WBSG1/1820 3.0x3.0m 8-WBSG1/3030 0.9x2.5m Roll WC-06693	1.0x2.3m Roll WC-06690 Can be easily cut to any desired length or shape
Specifications					
Fabric Type	Leather	Glass Fibre	Glass Fibre	Silica Glass	Special
Max Long Duration Resistance*	~200°C	~550°C	~800°C	~1100°C	~1200°C
Max Short Duration Resistance*	~250°C	~700°C	~1000°C	~1600°C	~1600°C
Nominal Weight	900-1100gsm	1000gsm	1100gsm	1200gsm	500gsm
Nominal Thickness	1.2mm	1.5mm	1.5mm	1.2mm	0.5mm
Applications	✓✓ Best Option ✓ Commonly Used • Sometimes Used ✗ Not Recommended	✓✓ Best Option ✓ Commonly Used • Sometimes Used ✗ Not Recommended	✓✓ Best Option ✓ Commonly Used • Sometimes Used ✗ Not Recommended	✓✓ Best Option ✓ Commonly Used • Sometimes Used ✗ Not Recommended	✓✓ Best Option ✓ Commonly Used • Sometimes Used ✗ Not Recommended
Grinding	✓	✓	✓	✓	✓
Light Welding & Cutting	✓	✓	✓	✓	✓
Medium Welding & Cutting	•	•	•	•	•
Heavy Welding, Cutting, Gouging	✗	✗	•	•	•
Stainless Welding	•	•	•	•	•
Stress Relieving / Heat Retention	✗	✓	✓	✓	✗
Drape or Screen	✓✓	✓	✓	✓	✓



More Info

*Temperature resistance is indicative only and can vary depending on usage conditions. A safety margin should be allowed for, especially in critical applications. Blankets are not indestructible and will wear and degrade over time. If protecting critical or costly surfaces / items, always use more layers initially and test on a non-critical surface first. When using for surface protection use on an incline of at least 15 degrees, or when necessary to use in horizontal position add more layers. Where the blanket is in closer proximity to the source of sparks etc, consider using more layers for added protection. Worn or damaged blankets will compromise protection and should be replaced. Use hand, eye and respiratory protection during handling and use. As applications and usage conditions vary widely, no warranty or fitness for use in any specific application is implied or intended.

PROMAX LEATHER

Welding Blankets

- Heavy duty split cowhide leather
- Sewn with heat-resistant Kevlar thread, for resistance to seam failure
- For protection against grinding sparks, light to medium spatter, indirect heat
- NOT recommended for protection against slag or molten droplets or direct flame



Part No.	Description
8-LWB1	1.0m x 2.0m (no eyelets)
8-LWB1818	1.8m x 1.8m with Eyelets
8-LWB2	2.0m x 2.0m with Eyelets
8-LWB3	3.0m x 3.0m with Eyelets

PROMAX WB550

General Purpose Welding Blankets

- Withstands up to 550°C long duration and 700°C short duration exposure
- Glass fabric, heat-treated to remove organic binders, set the weave, reduce fraying & reduce irritation
- For protection against sparks and light-to-medium welding spatter, etc
- Also used for heat treatment / stress relieving / heat retention (wrapping of heated objects to slow cooling)
- Gives off very minimal gas/fumes when burned, for safer use and to prevent surface contamination when used to wrap objects
- Heavy 1000 gsm fabric for increased durability and insulating properties



Part No.	Description
8-WB550/1018	Blanket 1.0m x 1.8m
8-WB550/1820	Blanket 1.8m x 2.0m with Eyelets
8-WB550/2030	Blanket 2.0m x 3.0m
WC-06686	Roll 24m x 1.0m

PROMAX WB1000

Medium-Duty Welding Blankets

- Withstands up to 800°C long duration / 1000°C short duration exposure
- Specially treated glass fabric for higher temperature resistance
- For protection against medium-to-heavy sparks & spatter, etc
- Provides higher temperature resistance than standard glass fibre fabric, without the higher cost of silica
- Also used for heat treatment / stress relieving / heat retention (wrapping of heated objects to slow cooling)
- Gives off very minimal gas/fumes when burned, for safer use and to prevent surface contamination when used to wrap objects
- Strong and abrasion resistant
- Heavy 1,200 gsm fabric for longer service life, durability, and better insulating properties



Part No.	Description
WC-06688	Blanket 1.8 x 0.9m
WC-06689	Blanket 1.8 x 1.8m

PROMAX WB1100

Heavy-Duty Silica Welding Blankets

- Max recommended working temperature / exposure: 1100°C
- Max short term / momentary heat resistance: ~1600°C
- For protection against heavier sparks & spatter, etc
- Also used for heat treatment / stress relieving / heat retention (wrapping of heated objects to slow cooling)
- Gives off very minimal gas/fumes when burned, for safer use and to prevent surface contamination when used to wrap objects
- Heavy 1200 gsm fabric for increased durability and insulation properties
- Softer and more flexible than glass fibre fabrics



Part No.	Description
8-WBSG11/0918	Blanket 1.8 x 0.9m
8-WBSG11/1820	Blanket 1.8 x 2.0m with Eyelets
8-WBSG11/3030	Blanket 3.0 x 3.0m
WC-06693	Roll 25m x 0.9m

PLATINUM WB1250+

Heavy-Duty Welding Blankets

- High-tech proprietary coating provides superior performance & safety vs most other types of high-temperature blankets
- Max recommended working temperature / exposure: 1200°C
- Max short term / momentary heat resistance: ~1600°C
- Coating on both sides of blanket completely seals / impregnates base fibres, providing a smooth, non-hairy finish
- Non-irritant, very safe, comfortable and easy to handle
- Resists spark penetration between fibres that can occur with other blankets
- Does NOT shed dust / fibres, which is an eye / skin / respiratory hazard associated with most other high-temp blankets
- Does not give off toxic / harmful fumes when in contact with heat / flame
- Smooth surface enables spatter and dross to cascade away, when used as a drape with blanket on an inclined surface
- Strong, durable, tear-resistant, and abrasion-resistant
- Lightweight whilst offering protection that would usually only be achieved with much thicker & heavier fabrics
- Safer & easier handling and transport (1x23m roll weighs ~12kg), compared to other blanket rolls that can weigh up to 50kg or more
- Resistant oils and solvents (which can contaminate blankets and become a fire hazard)
- Can be easily cut to any required length or shape using knife or scissors, leaving a smooth edge that resists fraying, and with no shedding of raw fibres that cause irritation



Withstands 1200°C long / 1600°C short exposure



High-tech proprietary coating provides superior performance & safety



Non-irritant & easy to handle



Does not shed dust/fibres or give off toxic fumes



Strong, durable, lightweight, flexible



Resistant to oils, solvents, etc



Easy to cut to required length, resists fraying

Part No.	Description
WC-06690	1.0x23m Roll

CONSUMABLES



PLATINUM 12V

GP Steel Electrodes

- Excellent Operator Appeal: Very smooth & stable arc, easy striking, low spatter, self-detaching / easy-to-remove slag
- User Friendly: Tolerant to dirty / rusty steel & poor fit up
- All-Positional: Fast-freezing slag for fillet & butt welding in all positions, including vertical-down
- Ideal General Purpose electrode for fabrication, repair, fencing, light structural & more
- Unbeatable Performance on: Mild, galvanized, plate, sheet & tubular/RHS steel
- Classifications: AWS A5.1 E6013 / AS/NZS 1553.1 E4112-0



Part No.	Description
2-E12V/26	2.6mm 2.5kg
2-E12V/32	3.2mm 5kg
P2-E12V/20HP	2.0mm Handy Pack (25 Rods)
P2-E12V/26HP	2.6mm Handy Pack (14 Rods)
P2-E12V/32HP	3.2mm Handy Pack (9 Rods)



“Have been welding for 50 years and never had rods so easy to use”

- Charlie, NSW

PROMAX GP

GP Steel Electrodes

- General purpose welding of mild & galvanised steel
- Smooth arc, easy re-striking & self-releasing slag
- Fast-freezing slag for welding in all positions
- Heavy-Duty re-usable plastic packet
- Classifications: AWS E6013 / AS:E4112



“Easy to strike and good fill with poor match-up. Best I have had in 29 years of welding”

- Rodney, QLD



Part No.	Description
WC-06296	2.0mm 1kg Re-usable Pack
WC-06297	2.6mm 1kg Re-usable Pack
WC-06298	3.2mm 1kg Re-usable Pack

PROMAX 16LH

Low-Hydrogen Steel Electrodes

- Low-hydrogen, for mild or high-strength steel, where the joint requires higher strength than standard GP electrodes
- Convenient 1kg heavy-duty re-usable plastic packs keeps electrode in good condition prior to use
- All-positional, except for vertical-down
- Classification: AWS E7016



Part No.	Description
WC-03152	2.6mm 1kg Re-usable Pack
WC-03153	3.2mm 1kg Re-usable Pack
WC-03154	4.0mm 1kg Re-usable Pack

PLATINUM 16XT

Low Hydrogen Steel Electrodes

- Hydrogen controlled (“low hydrogen”) with a special Twin Flux Coating for superior arc stability
- Foil-Sealed 2kg vacuum packs minimises waste and moisture exposure
- Commonly used for mild or high strength steel, where the joint requires higher strength than regular “GP” electrodes, providing a tensile strength of up to 510 MPa.
- All-Positional (except for vertical down), easy striking & smooth running
- Also used as a buffer layer prior to hard facing
- Classifications: AWS A5.1 E7016, AS/NZS 1553.1 E4946



Part No.	Description
WC-03974	2.5mm 2kg Vac Pack
WC-03975	3.2mm 2kg Vac Pack
WC-03976	4.0mm 2kg Vac Pack



“nice smooth rods to weld with in all positions, easy to strike”

- Ashley, WA

PLATINUM 316L

Stainless-Steel Electrodes

- Welding of matching 316, 316L and common “300 series” stainless steels, including; 301, 302, 304, 304L, 3Cr12 etc.
- Good resistance to pitting, acids and general corrosion.
- Heavy-Duty re-usable plastic packet
- All position, except vertical-down
- Classification: AWS E316L-16



Part No.	Description
WC-06453	2.0mm 1kg Re-usable Pack
WC-06454	2.6mm 1kg Re-usable Pack
WC-06455	3.2mm 1kg Re-usable Pack
P2-316L26	2.6mm Handy Pack (10 Rods)
P2-316L32	3.2mm Handy Pack (8 Rods)

PLATINUM 309MoL

Stainless-Steel Electrodes

- Welding of Stainless to mild or low alloy steels, matching 309 & 309L stainless, CrNi & CrNiMo stainless & hard to weld steels
- Also used for cladding & buffer layers
- Strong, tough & corrosion resistant
- Heavy-Duty re-usable plastic packet
- All position, except vertical-down
- Classification: AWS E309MoL-16



Part No.	Description
WC-06466	2.6mm 1kg Re-usable Pack
WC-06447	3.2mm 1kg Re-usable Pack

PLATINUM 312

Universal Electrodes

- High strength welding of almost any type of steel.
- Ideal for; Unknown steels, Dissimilar steels (e.g. steel to stainless), Die or tool steel, etc.
- Also used as a buffer layer prior to hardfacing etc.
- Heavy-Duty re-usable plastic packet
- All position, except vertical-down
- Classification: AWS E312-16



Part No.	Description
WC-06294	2.6mm 1kg Re-usable Pack
WC-06295	3.2mm 1kg Re-usable Pack
P2-31226	2.6mm Handy Pack (10 Rods)
P2-31232	3.2mm Handy Pack (8 Rods)

PLATINUM NiFe

Cast Iron Electrodes

- High strength welding of; cast iron (incl. grey / malleable, nodular & SG iron) & cast iron to steel
- Heavy-Duty re-usable plastic packet
- Horizontal & flat positions only
- Classification: AWS ENiFe-CI



Part No.	Description
WC-06299	3.2mm 1kg Re-usable Pack
P2-NCI32	3.2mm Handy Pack (9 Rods)

PROMAX 700

Hardfacing Electrodes

- General purpose hardfacing of ground-engaging implements and similar applications, including; augers, pints, tynes, blades and parts subject to fatigue or flexing
- Typical hardness 53-56 HRC (1st layer)
- Heavy-Duty re-usable plastic packet
- Horizontal & flat positions only
- For longer service life against abrasion, use Platinum 943 electrodes



Part No.	Description
WC-06444	3.2mm 1kg Re-usable Pack
WC-06476	4.0mm 1kg Re-usable Pack

PLATINUM 943

Hardfacing Electrodes

- High-performance hardfacing, for longer service life. Offers both exceptional abrasion resistance & moderate-to-heavy impact strength.
- Applications include bucket lips, screws, hammers, teeth, etc.
- Typical hardness 60-65 HRC (1st layer)
- Heavy-Duty re-usable plastic packet
- Horizontal & flat positions only



Part No.	Description
WC-06445	3.2mm 1kg Re-usable Pack
WC-06477	4.0mm 1kg Re-usable Pack

PLATINUM GL-11®

Gasless Wire

- Suitable for single or Multi-Pass welds
- Easy to use, even on steel that is slightly rusty or dirty and on painted steel surfaces
- All positional wire, for use on mild and galvanised steel
- Ideal for portable use - no gas required
- Ideal for outdoor or onsite use and welding in windy conditions
- Classification: AWS A5.20 E71T-11

Vacuum Foil-Sealed Spools

For exceptional storage life

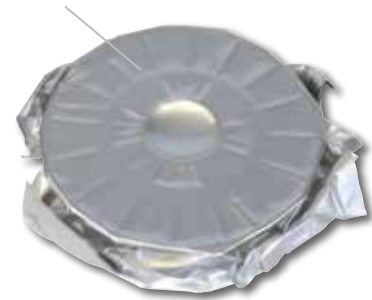

Platinum Performance

Rated by thousands of Aussie fabricators as Australia's No. 1 Gasless Wire!

Many Applications

For All-Positional, Single and Multi-Pass welds. Ideal for mild or galvanised steel



Ultra-Smooth & Easy to Use!

Very smooth arc, Minimal spatter, Easy-to-remove slag. Tolerant to variations in machine settings, quick & easy to set up

Low Fume

Reduced fume volume vs other brands



“Tried all brands in my trade as a boilermaker. GL-11 is the only one I use. Perfect result every bead, marginal spatter and flux that flakes off. Not worth the dramas of dealing with other brands quality issues”

- Chris, WA



Part No.	Description
2-088FM	200mm/4.5kg Spool 0.8mm
2-098FM	200mm/4.5kg Spool 0.9mm
2-128FM	200mm/4.5kg Spool 1.2mm
2-GWS1115/09	300mm/15kg Spool 0.9mm
2-GWS1115/12	300mm/15kg Spool 1.2mm
2-GWS1115/16	300mm/15kg Spool 1.6mm

PROMAX E-21

Gasless Wire

- Suitable for all-positional, single and multi-pass welds
- For welding mild & galvanized (Gal) steels
- Ideal for portable use - no gas required
- Ideal for outdoor or onsite use and welding in windy conditions
- Premium E71T-11 industrial grade
- Classification: AWS A5.20 E71T-11



**“This is my 3rd roll...
Very user-friendly
and consistent”**

- Ashley, NSW

Part No.	Description
WC-00259	200mm/4.5kg Spool 0.8mm
WC-00260	200mm/4.5kg Spool 0.9mm

MINI-SPOOLS

Gasless Wire

- Easy to use even on steel that is slightly rusty or dirty
- All positional wire, for general purpose use on mild and galvanised steel
- Industrial grade E71T-11
- Suitable for single or multi-pass



Part No.	Description
P2-084FM	100mm/0.9kg Spool 0.8mm
P2-094FM	100mm/0.9kg Spool 0.9mm

MINI SPOOLS

Steel MIG Wire

- Premium S6 grade, copper coated low carbon steel MIG wire for welding a wide range of mild and mid strength steels



Part No.	Description
P2-084MW	100mm/1.0kg Spool 0.8mm
P2-094MW	100mm/1.0kg Spool 0.9mm

PLATINUM XT6

Steel MIG Wire

- Excellent operator appeal
- Excellent feedability, Low spatter & low fume
- Premium S6 grade, layer wound copper coated low carbon steel mig wire
- For welding a wide range of mild and mid strength low carbon steels and galvanised steel
- All-positional
- Classification: AWS A5.18 ER70S-6



Part No.	Description
2-XMS608/06	200mm/5kg Spool 0.6mm
2-XMS608/08	200mm/5kg Spool 0.8mm
2-XMS608/09	200mm/5kg Spool 0.9mm
WC-03137	300mm/15kg Spool 0.9mm

PLATINUM 71XM

Flux-Cored Wire

- Smooth arc, low spatter, easy de-slagging, all-positional
- Commonly used for heavy construction, equipment repair, welding high strength steels, etc
- Use with Ar+CO2 mixed gas, or 100% CO2 gas
- Classification: AWS E71T-1M/1C



Part No.	Description
WC-05362	300mm/15kg Spool 1.2mm
WC-05364	300mm/15kg Spool 1.6mm

PLATINUM 316Lsi

Stainless Steel MIG Wire

- For welding many 300 & 400 series stainless steels
- Excellent edge wetting & arc stability
- Classifications: AWS ER 316LSi, AS/NZS ISO 14343 B SS316LSi



Part No.	Description
P2-MW316L04/08	100mm/1.0kg Spool 0.8mm
P2-MW316L04/08	100mm/1.0kg Spool 0.9mm
2-MW316L08/08	200mm/5kg Spool 0.8mm
2-MW316L08/09	200mm/5kg Spool 0.9mm
2-MW316L12/09	300mm/12.5kg Spool 0.9mm

PLATINUM 309Lsi

Stainless Steel MIG Wire

- Ductile and crack resistant
- For: Dissimilar welding of “300 series” stainless steels to mild steel, Matching 309/309L grades, Intermediate layer in butt welding of clad steel
- Higher silicon content for arc stability
- Classifications: AWS ER 309LSi, AS/NZS ISO 14343: B SS309LSi, Ferrite Number about 10-15 FN



Part No.	Description
WC-03194	300mm/12.5kg Spool 0.9mm

PROMAX 5356

Aluminium MIG Wire

- General purpose aluminium wire for welding a wide range of cast & wrought aluminium alloys.
- For welding a wide range of 5xxx series and some 6xxx series alloys
- Classifications:
AWS 5.10 ER5356
AS/NZS ISO 18273 - S Al 5356



Part No.	Description
P2-MW535604/09	100mm/0.45kg Spool 0.9mm
P2-MW535604/10	100mm/0.45kg Spool 1.0mm
P2-MW535604/12	100mm/0.45kg Spool 1.2mm
2-MW535608/09	200mm/2kg Spool 0.9mm
2-MW535608/10	200mm/2kg Spool 1.0mm
2-MW535608/12	200mm/2kg Spool 1.2mm
2-MW535612/09	300mm/6kg Spool 0.9mm
2-MW535612/10	300mm/6kg Spool 1.0mm
2-MW535612/12	300mm/6kg Spool 1.2mm

PROMAX 5183

Aluminium MIG Wire

- High strength & toughness, especially at lower temperatures
- Excellent corrosion resistance due to slightly lower magnesium content (vs 5356 wire)
- Higher wire strength & better feedability
- Welding alloys such as 5083, 5086, 5456, to each other or to 5052, 5652 and 5056
- Classifications:
AWS 5.10 ER5183
AS/NZS ISO 18273 - S Al 5183



Part No.	Description
WC-06644	300mm/6kg Spool 1.2mm

PROMAX 4043

Aluminium MIG Wire

- Excellent crack resistance
- Added silicon content (5%) increases fluidity of the weld pool
- Lower melting point and fluidity vs 5xxx series wires
- Preferred by some welders for an aesthetically superior weld finish
- Low welding smut and discoloration
- Low shrinkage rate/reduced distortion
- For welding a wide range of 4xxx, 5xxx & 6xxx series alloys
- Classification: AWS 5.10 ER4043



Part No.	Description
WC-02598	300mm/6kg Spool 1.0mm
WC-02599	300mm/6kg Spool 1.2mm



PLATINUM SD-980

Hardfacing Wire (Solid)

- Versatile & easy-to-use “all-rounder”
- Ideal for applications where abrasion resistance is required - especially when accompanied by shocks and blows, e.g. excavator buckets and teeth, screws and augers, tracks, crushing jaws/ wheels, etc.
- All positional welding
- Also suitable for metal-to-metal wear
- Use with Ar+CO2 mixed gas
- For longer service life against abrasion, use Platinum CX-1800 wire or CX-2150 wire



PLATINUM CX-1800

Hardfacing Wire (Gasless)

- High Chromium content plus special proprietary additive provides very high wear resistance against abrasion
- 3-4x better wear life vs basic hardfacing wires
- Ideal for metal-to-earth where wear is mostly caused by abrasion with low/medium impact
- Gasless wire for easy application in the field or workshop
- Suitable for use with smaller/portable MIG welders (requires Max 180-200 Amps)



Part No.	Description
WC-03764	1.2mm 4.5kg/200mm Spool
WC-03765	1.2mm 15kg/300mm Spool

Part No.	Description
WC-03766	1.2mm 4.5kg/200mm Spool
WC-03767	1.2mm 15kg/300mm Spool

PLATINUM CX-2150

Hardfacing Wire (Gasless)

- Extreme performance: Up to 6-7 times longer wear life vs basic hardfacing wires
- Offers unique combination of both extreme abrasion resistance AND very high impact resistance
- Suits a very wide range of applications, including components subject to abrasion together with high impact stress
- Longer wear life = reduced down-time = considerable productivity cost savings
- Requires minimum 160 amps, suitable for use with MIG welders around 200A-250A & above
- Gasless wire for easy application in the field or workshop



Part No.	Description
WC-03791	1.6mm 12.5kg (300mm spool)

STEEL S6

Filler Rod

- For general TIG welding or oxy/acetylene fusion welding of mild steels
- AWS Classification A5.18 ER70S-6



Part No.	Description
WC-03782	1.6mm - 1.0kg Handy Pack
WC-03783	2.4mm - 1.0kg Handy Pack

STAINLESS STEEL 316L

Filler Rod

- For TIG welding common 300 series stainless steels, such as 301, 302, 304, 304L, 316, 316L also 409, 444 and 3cr12.
- AWS Classification A5.9 ER 316L



Part No.	Description
WC-02373	1.6mm - 1.0kg Handy Pack
WC-00235	1.6mm - 5.0kg Bulk Pack
WC-02452	2.4mm - 1.0kg Handy Pack
WC-00236	2.4mm - 5.0kg Bulk Pack

STAINLESS STEEL 316L

Filler Rod

- For TIG welding common 300 series stainless steels, such as 301, 302, 304, 304L, 316, 316L also 409, 444 and 3cr12.
- AWS Classification A5.9 ER 316L



Part No.	Description
WC-02373	1.6mm - 1.0kg Handy Pack
WC-00235	1.6mm - 5.0kg Bulk Pack
WC-02452	2.4mm - 1.0kg Handy Pack
WC-00236	2.4mm - 5.0kg Bulk Pack

ALUMINIUM 5356

Filler Rod

- For a wide range of aluminium alloys, general aluminium fabrication and repair
- 5% Magnesium content
- AWS Classification A5.10 ER 5356



Part No.	Description
WC-01535	1.6mm - 0.5kg Handy Pack
WC-00221	1.6mm - 5.0kg Bulk Pack
WC-02308	2.4mm - 0.5kg Handy Pack
WC-00222	2.4mm - 5.0kg Bulk Pack
WC-02309	3.2mm - 0.5kg Handy Pack



GOUGING CARBONS

- Designed for gouging and cutting most steels
- High speed process
- Removal of weld material, cracks or defects removal
- Operates on DC welding power source and requires air arc gouging torch with compressed air supply



Part No.	Description
2-GC5	5mm (3/16") Box 50
2-GC65	6.5mm (1/4") Box 50
2-GC8	8mm (5/16") Box 50
2-GC95	9.5mm (3/8") Box 50
2-GC13	13mm (1/2") Box 50

SILVER 2% Braze Rod

- Joining copper to copper - can be used without flux, due to phosphorous content
- Joining copper to low zinc brass - flux required
- Popular for copper pipe, plumbing fittings, hot water tanks
- Economical



Part No.	Description
WC-06357	2.4mm Bare - Handy Pack - 5 Rods

SILVER 15% Braze Rod

- Joining copper to copper - can be used without flux, due to phosphorous content
- Joining copper to brass - flux required
- Commonly used in plumbing & HVAC applications; copper pipe, hot water tanks, etc
- Suitable for gap filling



Part No.	Description
WC-060787	2.4mm Bare - Handy Pack - 5 Rods

SILVER 45% Braze Rod

- General purpose low temperature brazing
- High strength joining of steel, stainless, copper, brass, etc



Part No.	Description
P2-SB4516B/2	1.6mm Bare - 2 Rods
P2-SB4516B/5	1.6mm Bare - 5 Rods
WC-00209	1.6mm Bare - 0.5kg Pack
P2-SB4516F/2	1.6mm Flux Coated - 2 Rods
P2-SB4516F/5	1.6mm Flux Coated - 5 Rods
WC-00210	1.6mm Flux Coated - 0.5kg Pack

MANGANESE BRONZE Braze Rod

- For steel, cast iron, malleable iron, copper, copper alloys
- Not suitable for hot or salt water pipes



Part No.	Description
P2-FRMB24B/10	2.4mm Bare - 10 Rods
P2-FRMB24F/10	2.4mm Flux Coated - 10 Rods
P2-FRMB32B/10	3.2mm Bare - 10 Rods
P2-FRMB32F/10	3.2mm Flux Coated - 10 Rods

NICKEL BRONZE Braze Rod

- High strength & good wear resistance
- For steel, cast iron, copper, copper alloys, etc
- Popular for build up of worn components, e.g. gear teeth



Part No.	Description
P2-FRNS24F/10	2.4mm Flux Coated - 10 Rods
P2-FRNS32F/8	3.2mm Flux Coated - 8 Rods

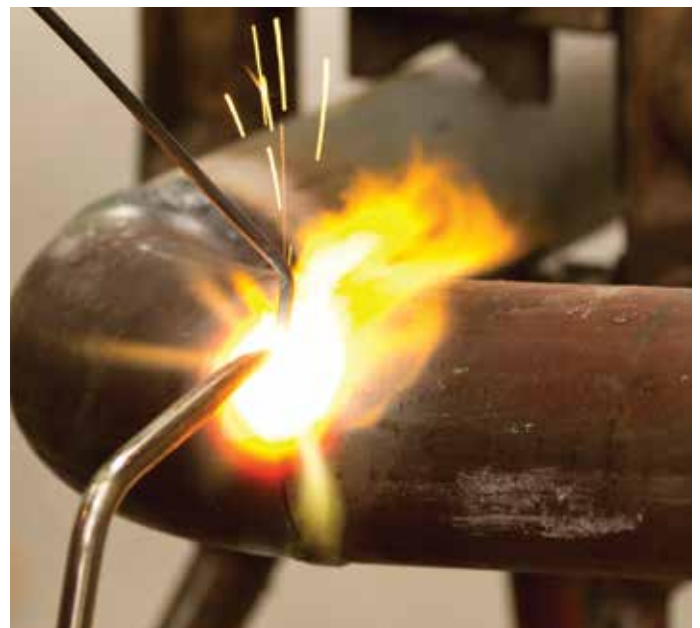

CONSUMABLES SELECTION GUIDES

**FIND THE RIGHT
CONSUMABLES
FAST**



weldclass.com.au/HandyTools

**BRAZING &
TIG ROD
SELECTION CHART**



**STICK
ELECTRODE
SELECTION CHART**



**HARDFACING
SELECTION GUIDE**

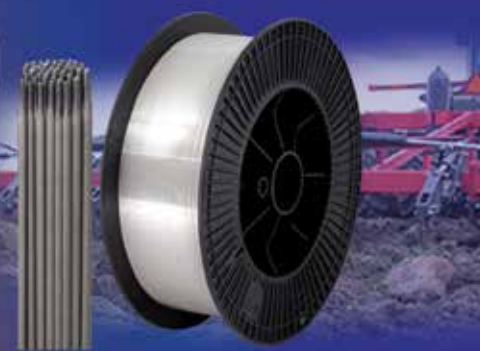

**ALUMINIUM
MIG WIRE
SELECTION CHART**

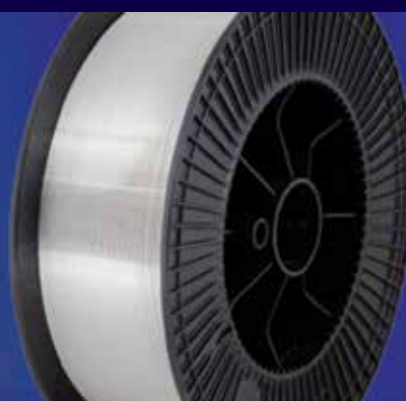

ACCESSORIES & TOOLS



EARTH CLAMPS

Standard

- Copper braided shunt for improved conductivity
- Suitable for MIG/STICK/TIG Welders

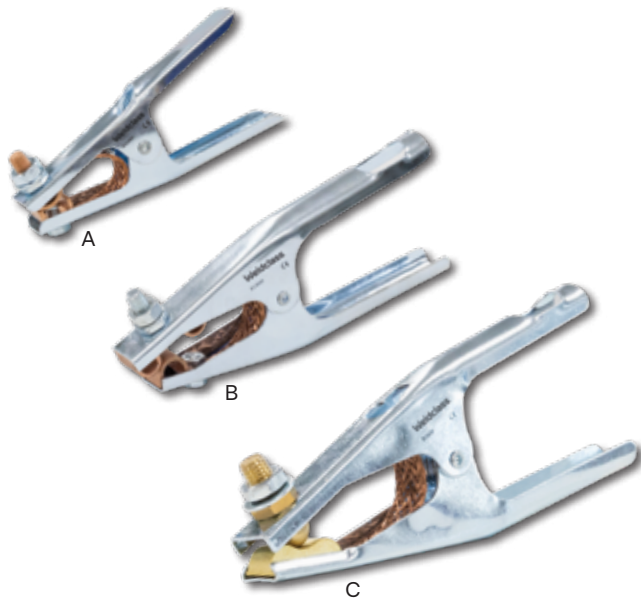

Part No.	Description	Ref
P6-EC200	200 Amp	A
P6-EC300	300 Amp	B
P6-EC500	500 Amp	C

PLATINUM HEAVY DUTY

Direct Fit Earth Clamps

- Fast & easy to fit - No cable lug required
- Robust and durable
- One-Piece cable terminal and jaw: Very direct current flow from the cable to the job



Part No.	Description
WC-01647	200 Amp H/Duty Direct Fit 250A @ 60% Suit Cable ≤35mm ²
P6-EC500H	500 Amp H/Duty Direct Fit 500A @ 60% Suit Cable ≤70mm ²

PLATINUM EC600H

H/Duty Earth Clamp

- Robust and durable
- For all types of welders up to 600 Amps
- Capacity: 600A @ 35%



Part No.	Description
WC-01532	600 Amp H/Duty

PLATINUM BRASS G-STYLE

Earth Clamps

- Solid brass construction = Very reliable earth connection & long service life
- Withstands high heat = For high duty-cycle operations
- Will not rust = Suitable for all environments, including field work
- Resists spatter build-up
- Copper spindle for better connection

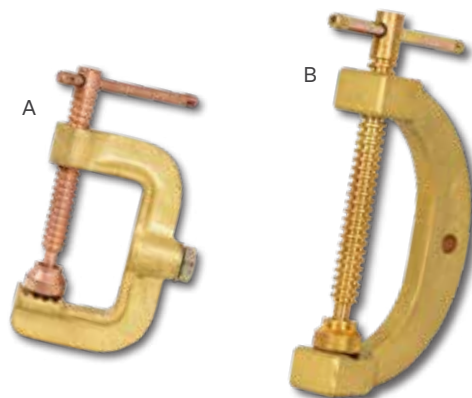

Part No.	Description	Ref
WC-06467	400 Amp Max Opening 57mm	A
WC-06468	600 Amp Max Opening 103mm	B

MAGNETIC

Earth Clamps

- 600 Amp rated
- Thermal protective sleeve
- Dual rotary feature – prevents cable from tangling
- Suits up to 95mm² cable
- Ideal for use on large items, sheet metal etc.



Part No.	Description
WC-06466	600 Amp

ELECTRODE HOLDERS

- Industrial quality
- Twist-lock style allows firm grip of electrode
- Tong/Alligator style allows single-handed grip & release of electrode

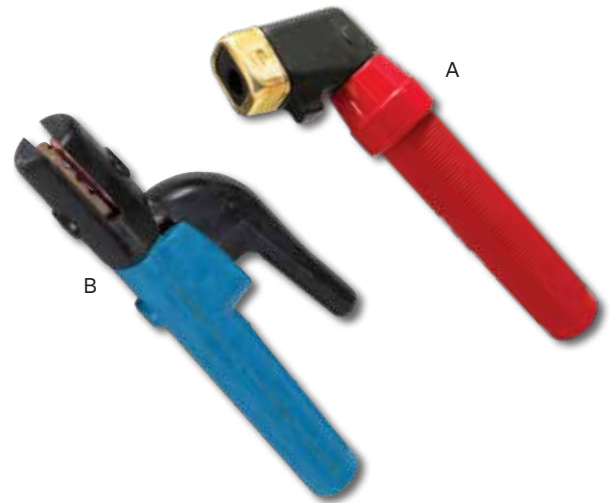

Part No.	Description	Ref
P6-TW400	Twist-Lock 400 Amp	A
P6-TW600	Twist-Lock 600 Amp	
P6-TG300	Tong 300 Amp	B
P6-TG500	Tong 500 Amp	

WELDING LEAD SETS

≤ 200 Amp

- Fitted with 10-25 style small connectors (Ø9mm pin)
- 4-meter length
- Double-insulated 16mm² cable
- Earth lead comes with heavy duty earth clamp

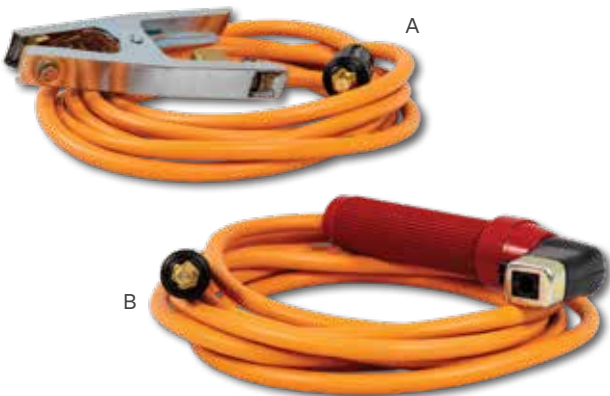

Part No.	Description	Ref
WC-06230	Earth Lead Assembly 200A	A
WC-06231	Work Lead Assembly 200A	B

WELDING LEAD SETS

≤ 280 Amp

- Fitted with 35-50 style large connectors (Ø13mm pin)
- 4-meter length
- Double-insulated 25mm² cable
- Earth lead comes with heavy duty earth clamp

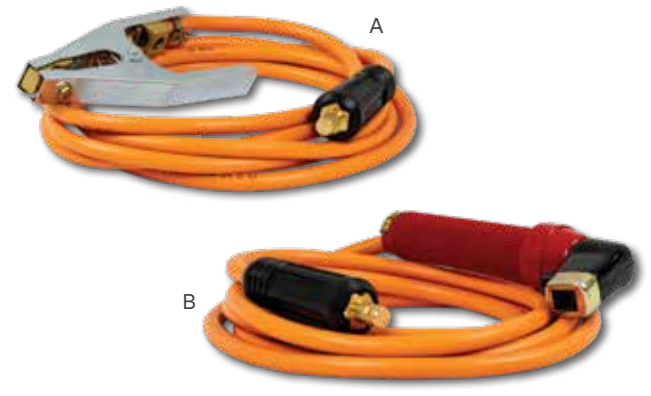

Part No.	Description	Ref
WC-06232	Earth Lead Assembly 280A	A
WC-06233	Work Lead Assembly 280A	B

CABLE CONNECTORS

Dinse Style

- Common Dinse style Twist-lock connector

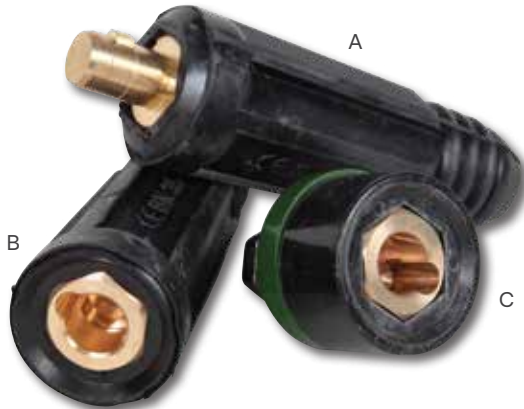

Part No.	Description	Type	Ref
P6-1025MC	"10-25"	Male	A
P6-1025FC	Suit cable up to 25mm ²	Female	B
P6-1025FP	Ø9mm male pin	Panel-Mount Female	C
P6-3550MC	"35-50"	Male	A
P6-3550FC	Suit cable up to 70mm ²	Female	B
P6-3550FP	Ø13mm male pin	Panel-Mount Female	C

CABLE JOINERS

500 Amp

- Commonly used on large engine-driven welders
- Compatible with other common brands



Part No.	Description	Colour	Suit Cable Size
WC-01499	Standard Male/female Set	Blue	Up to 70mm ²
WC-01493	Standard Female Only		
WC-01495	Standard Male Only		
WC-01867	Male/female Set	Red	50-95mm ²

CABLE LUGS

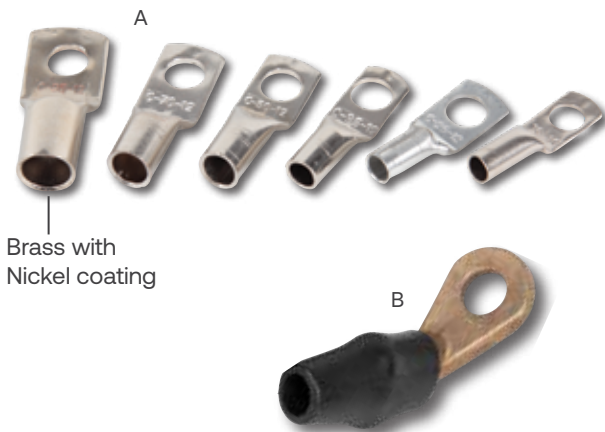

Brass with Nickel coating

Part No	Type	Ref	Suit Cable Size	Terminal Hole	Unit
P6-CL1610/2	Crimp or Solder Fit 16mm ² - Hole 10mm	A	16mm ²	10mm	Pk2
P6-CL2512/2			25mm ²	12mm	
P6-CL3512/2			35mm ²	12mm	
P6-CL5012/2			50mm ²	12mm	
P6-CL7012/2			70mm ²	12mm	
P6-CL9512/2			95mm ²	12mm	
P6-FL300	Brass Re-Usable	B	50mm ²	13mm	Each

WELDING CABLE

- Premium quality
- Double insulated
- High flexibility
- Ideal for welding lead sets & battery charging booster lead sets



Part No.	Description	Unit
6-WC16/100	16mm ² (170 Amp@30%)	Roll 100m
6-WC25/100	25mm ² (240 Amp@30%)	Roll 100m
6-WC35/100	35mm ² (310 Amp@30%)	Roll 100m
6-WC50/100	50mm ² (410 Amp@30%)	Roll 100m

PROMAX K4

Gouging Torch

- Robust, dependable design
- 800 amp capacity
- Highly efficient metal removal, defect repairs, crack removal, edge preparation, etc
- Use with gouging carbon rods + DC power source + compressed air
- Use with 5mm - 13mm gouging carbons



Gouging Torch Typical Set Up

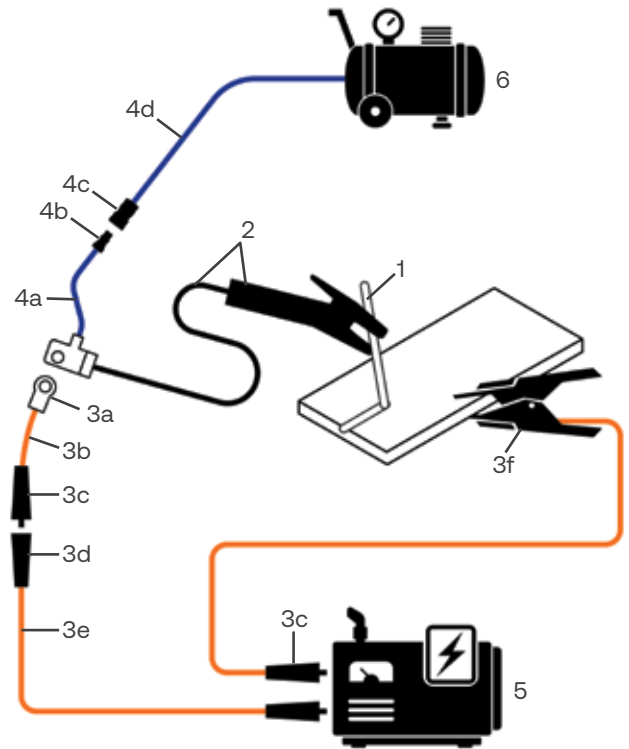

Part No.	Description
6-K4GT	Torch Complete with 2m Cable

Component	Comments
1 Gouging Carbon Rod	See page 54
2 Gouging Torch & Cable	Weldclass part no. 6-K4GT
3a Cable Lug	Attaches to gouging torch cable terminal. See page 60.
3b Short Length of Welding Cable	Typically <0.5m. Remains attached to gouging torch to allow fast disconnection.
3c Cable Joiner Male	500A Cable Joiners commonly used, see page 60.
3d Cable Joiner Female	Note connectors to welding machine may vary.
3e Long Length of Welding Cable	Length as per user preference (typically 10m+) Cable size 35-50mm ² or more, depending on machine output and/or gouging capacity required.
3f Earth Clamp	See pages 58-59
4a Short Length of Air Hose	10mm ID. Attaches to nipple on gouging torch terminal. Remains attached to gouging torch to allow fast disconnection.
4b Male Air Coupling	Type as per user preference (eg Nitto style).
4c Female Air Coupling	
4d Long Length of Air Hose	10mm ID. Length as per user preference (typically 10m+).
5 Welding Machine / Power Source	Minimum 300A output is required for gouging. Engine-drive welding machines are often used.
6 Air Compressor	Compressor size depends on gouging rod size & application, typically 20-50 CFM.



ENGINEERS CHALK

- Resists breakage & powdering - No wasting time with chalk that doesn't perform
- Consistently Top Quality - Expect the same quality every time
- Cost effective Non-permanent marking



Part No.	Description
6-EC7510	75 x 10 x 10mm Square -50 pcs/box
6-EC755	75 x 10 x 5mm Split -100 pcs/box
6-EC125	125 x 12 x 5mm Split -144 pcs/box (suit dispenser)
P6-ECD	Dispenser suits 6-EC125 Chalk

WELDERS PENCILS

- Superior to chalk: Won't rub or burn off
- Designed to mark in all conditions, even oily, rusty or wet surfaces
- Highly visible marks remain visible during cutting or welding
- Perfect for layout marking prior to cutting / welding / fitting
- Marks: Mild steel and most metals



Part No.	Description	Box Qty
ML-96101	Silver Streak Pencil	12
ML-96100	Red Riter Pencil	12

MARKAL® PAINT-RITER+ LOW CORROSION

Paint Pens

- Formerly "Pro-Line HP"
- Unsurpassed writing on challenging surfaces: Oily, Damp, Rusty, Coated & more
- Low-Chloride / Low-Corrosion Formula = Safe for use on stainless steel, alloys and other special metals and will not contribute to unwanted corrosion, degradation, or pitting from use
- Highly visible, extremely durable permanent paint that dries quickly and resists wearing or fading
- Made in USA
- ClipGrip Knurled Cap = Easy removal when wearing gloves or with greasy hands, will not roll on flat surfaces
- Marking Temp Range: -46°C to 66°C
- Industries: Metal Fabrication, Oil/Gas, Power/Energy, Shipbuilding, Aerospace, Nuclear
- Marks On: All metals, masonry, plastic, glass, ceramic, rubber & more
- 3mm medium bullet tip



Part No.	Description	Box Qty	Carton Qty
ML-96960	White	12	48
ML-96961	Yellow	12	48
ML-96963	Black	12	48
ML-96962	Red	12	48
ML-96965	Blue	12	48
ML-96966	Green	12	48
ML-96830	Pink	12	48

PAINT PENS

Carded

- Real paint with valve-actuated tip
- Individually Packaged / Carded for low-volume use
- Fast-drying permanent marks on all surfaces



Part No.	Description
P6-PMB	Black Valve-Action (Carded)
P6-PMW	White Valve-Action (Carded)
P6-PMY	Yellow Valve-Action (Carded)

RED ARROW MAGNETS

Promax MG10 Series



- 90 and 45 degree angle holding positions
- Assists positioning of metal plates, brackets, etc when welding

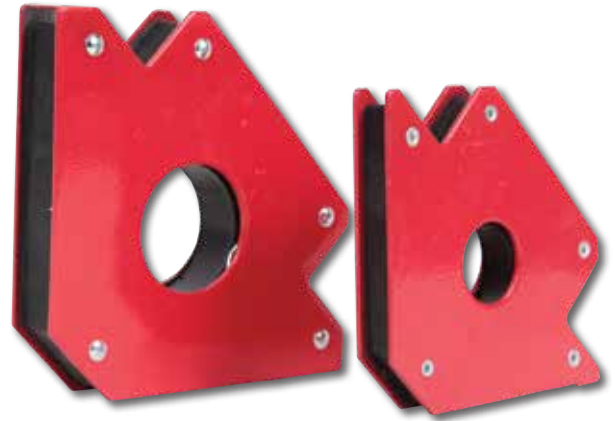

Part No.	Description
P6-AMH4	Promax MG14 112 x 112mm
P6-AMH5	Promax MG15 135 x 135mm

MINI MAGNETS

Promax MG12



- Low profile, height 60mm
- Ideal for holding work pieces at multiple points
- Max pull force of approx 12kg
- Aluminium clad enclosure for easy cleaning



Part No.	Description
WC-01875	2-Pack
WC-01876	6-Pack

ON-OFF MAGNETS

Promax MG20 Series



- On-off switch allows fast and safe positioning and removal
- Turn magnet Off or at the mid-point when setting up, turn On when in final position
- Ideal for flat, round and square steel profiles
- Easy to clean, simply turn off and wipe



Part No.	Description
WC-01885	MG22 110x95x25mm 90/45° max pull force approx 35-40kg
WC-01886	MG26 150x130x35mm 90°, 45° & 60/30° Multi-Angle, max pull force approx 65-70kg

PROMAX FHD F-CLAMPS

General Purpose

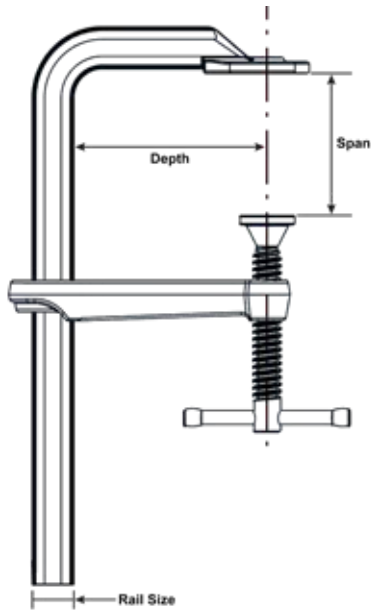

Threaded, Removable Stopper

Allows arm removal for confined spaces or larger objects

Part No.	Description
WC-01870	100mm Span x 80mm Depth (16x8mm Rail)
WC-01871	200mm Span x 80mm Depth (16x8mm Rail)
WC-01872	300mm Span x 120mm Depth (25x12mm Rail)
WC-01873	400mm Span x 180mm Depth (25x12mm Rail)
WC-01874	500mm Span x 120mm Depth (25x12mm Rail)

ANTI-SPATTER

Nozzle Dip Gel

- Advanced non-toxic gel formula
- 300g metal tin
- Helps maintain optimum gas coverage
- Prevents spatter adhering to MIG torch parts

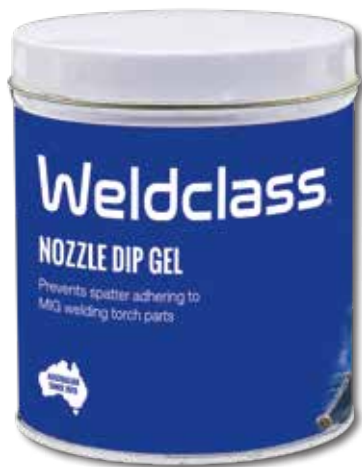

Part No.	Description
WC-06465	300g Metal Tin

ANTI-SPATTER FLUID

Concentrate

- Designed to stop spatter adhering to metal surfaces
- Water based & Non-toxic
- Paintable and anti-rust
- Concentrate can be diluted 1:1 with water



Part No.	Description
WC-06096	500ml spray pack
WC-06097	5L Container Concentrate
WC-06098	20L Container Concentrate

ELECTRODE DRYING OVEN

Portable 5-10kg Capacity

- Keeps electrodes moisture-free for optimum weld quality and electrode performance
- Round/Cylindrical chamber keeps electrodes in better condition & avoids flux chipping, unlike square shaped ovens where electrodes tend to roll from one corner to another and are more readily damaged
- Lightweight - less than 5kg (unloaded) = Reduced strain on operator
- Variable temperature 50-200°C
- Commonly used with Low-Hydrogen electrodes, so that low-hydrogen status is not compromised through moisture contamination
- Suitable for all types of electrodes



Part No.	Description
WC-01550	Capacity: Up to 10kg

CHIPPING HAMMER

- Spring handle
- Hardened steel head



Part No.	Description
6-SHCH	Spring Handle

MIG PLIERS

- Multi purpose plier ideal for use when mig welding
- 4 in 1: Wire cutting, nozzle and tip removal, nozzle cleaning & light hammering



Part No.	Description
P6-MPLY	MIG Pliers

CENTERING HEADS

Contour Curv-O-Mark

- Used most often for finding top dead center or bottom dead center on pipe
- Also used to mark the location of other angle points



Part No.	Description
KC-J1879	Standard No. 6 100mm
KC-J1880	Jumbo No. 7 200mm

WRAP-A-ROUNDS

Contour Curv-O-Mark

- Inexpensive tool for marking straight lines around pipe, or for use as a straight edge
- Printed with scale, pitch chart, tangent chart and other useful markings
- Withstands service temperature of up to 180°C



Part No.	Description	Wrap Size	Suit Pipe Dia.
KC-J1858	164B Medium	100x1220mm	Up to 320mm
KC-J1859	176B Large	100x1830mm	Up to 480mm
KC-J1860	177B XL	125x2130mm	Up to 560mm
KC-J1861	179B XXL	125x2740mm	Up to 720mm

DIAL ANGLE FLANGE LEVEL

Contour Curv-O-Mark

- Versatile tool that can be used as a dial degree utility level or, with attachments, for two-holing flange alignment.
- Fitted with a threaded, self-aligning conical spacer and conical nut and bolt units for fastening the level to a pipe flange



Part No.	Description
KC-J1891	Dial Angle Flange Level No. 20

UNIVERSAL LEVEL (MAGNETIC)

Contour Curv-O-Mark

- Valuable multi-purpose tool for assisting in a range of pipefitting tasks
- Adjustable 360° protractor-dial level allows use in any position
- Magnetic



Part No.	Description
KC-J1904	Universal Level No. 33

CONTOUR MARKERS

Contour Curv-O-Mark

- Compact, time-saving tool used for layout marking of pipe and structural steel joints.
- Laterals at any angle, tees, wyes, crosses, elbows-any type or size of joint can be quickly and precisely laid out



Part No.	Description
KC-J1874	Standard No. 1
KC-J1877	Jumbo No. 4

CONTOUR PRO-MAG LEVEL

Contour Curv-O-Mark

- Lightweight, easy to use tool for determining and setting up angles
- Ideal for pipefitters and welders
- Magnetic
- 360° adjustable dial level (DSL) with two 90° quadrants graduated in 2-1/2-degree increments
- Cast in are tables used to convert degree-of-angle to rise-in-inches-per-foot or millimeters-per meter



Part No.	Description
KC-J1881	Pro-Mag Level No. 8

MIG TORCHES & SPARES



BZL 15

MIG Torches & Parts

- 180 Amp max capacity (150A @ 60% duty cycle, using mixed argon gas)
- Ideal for Light Fabrication



Ref	Part No.	Description
-	WC-03609	Complete Torch 3m with Euro Connection
-	WC-03610	Complete Torch 4m with Euro Connection
A	WC-01643	Consumable Parts Kit
-	P3-B15SN	Neck Pk1 (ref 002.0009)
B	P3-B15N	Nozzle Conical 12mm Pk2 (ref 145.0075, W6000600)
	P3-B15NC	Nozzle Cylindrical 16mm Pk2 (ref 145.0041)
C	P3-B15NS	Nozzle Spring Pk2 (ref 002.0058)
D	-	Tips - See Page 70
E	P3-B15TH	Tip Holder LH Thread Pk2 (ref 002.0078, W6000605)
	WC-00429	Tip Holder RH Thread Pk2 (ref W6000606)
-	-	Liners - See Page 70 & 76



BZL 24

MIG Torches & Parts

- 240 Amp Capacity (220A @ 60% duty cycle, using mixed argon gas)
- Mid size torch suits most 240V (single phase) MIG welders
- Ideal for medium fabrication and repair work

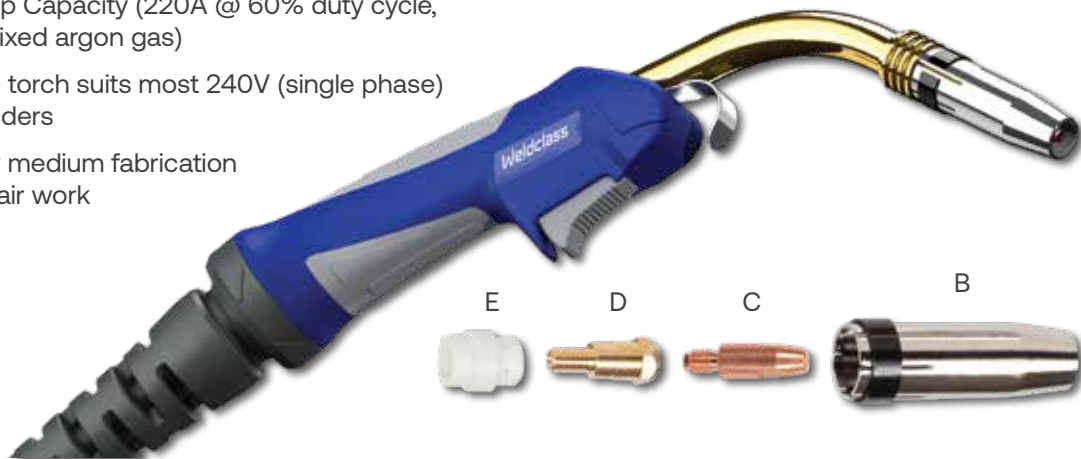

Ref	Part No.	Description
-	WC-03611	Complete Torch 3m with Euro Connection
-	WC-03612	Complete Torch 4m with Euro Connection
A	WC-01644	Consumable Parts Kit
-	P3-B24SN	Neck Pk1 (ref 012.0001)
B	P3-B24N	Nozzle Conical 12.5mm Pk2 (ref 145.0080)
	P3-B24NC	Nozzle Cylindrical 16mm Pk2 (ref 145.0047)
C	-	Tips - See Page 70
D	P3-B24TH	Tip Holder Pk2 (ref 142.0003)
E	P3-B24GD	Gas Diffuser Pk2 (ref 012.0183)
-	-	Liners - See Page 70 & 76



BZL 25

MIG Torches & Parts

- 230 Amp Capacity (200A @ 60% duty cycle, using mixed argon gas)
- Mid size torch suits most 240v (single phase) MIG welders
- Ideal for medium fabrication and repair work



Ref	Part No.	Description
-	WC-03614	Complete Torch 3m with Euro Connection
-	WC-03615	Complete Torch 4m with Euro Connection
A	WC-01645	Consumable Parts Kit
-	P3-B25SN	Neck Pk1 (ref 004.0012)
B	P3-B25N	Nozzle Conical 15mm Pk2 (ref 145.0100)
C	-	Tips - See Page 70
D	P3-B25TH	Tip Holder Pk2 (ref 142.0001)
E	P3-B25NS	Nozzle Spring Pk2 (ref 003.0013)
-	-	Liners - See Page 70 & 76



BZL 36

MIG Torches & Parts

- 320 Amp Maximum Capacity (270A @ 60% duty cycle, using mixed argon gas)
- Heavy duty torch suitable for production welding

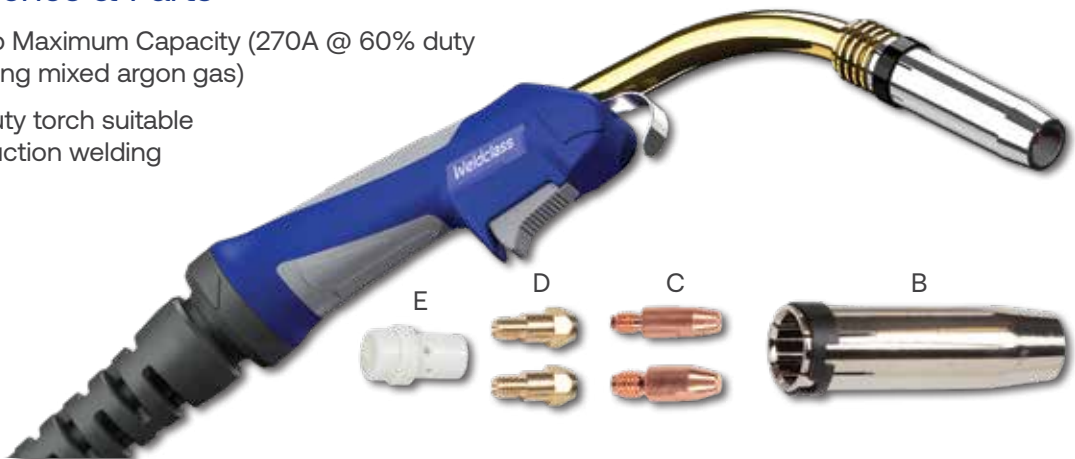

Ref	Part No.	Description
-	WC-03617	Complete Torch 3m with Euro Connection
-	WC-03618	Complete Torch 4m with Euro Connection
-	WC-03619	Complete Torch 5m with Euro Connection
A	WC-01646	Consumable Parts Kit
-	P3-B36SN	Neck Pk1 (ref 014.0006)
B	P3-B36N	Nozzle Conical 16mm Pk2 (ref 145.0078)
C	-	Tips - See Page 70
D	P3-B36TH6	Tip Holder for M6 Tips Pk2 (ref 142.0005)
	P3-B36TH8	Tip Holder for M8 Tips Pk2 (ref 142.0020)
E	P3-B36GD	Gas Diffuser Std White Pk2 (ref 014.0261)
-	-	Liners - See Page 70 & 76



BZL MIG TIPS

M6x6

- Suitable for BZL 15, 24 & 25 style MIG torches.
- M6 (6mm) thread and 6mm body



Part No.	Description
P3-BT6066	0.6mm Pk5 (ref 140.0008)
P3-BT6086	0.8mm Pk5 (ref 140.0059)
P3-BT6096	0.9mm Pk5 (ref 140.0177)

BZL MIG TIPS

M6x8

- Suit BZL 24, 25, 26, 36 style MIG torches
- M6 (6mm) thread & 8mm body

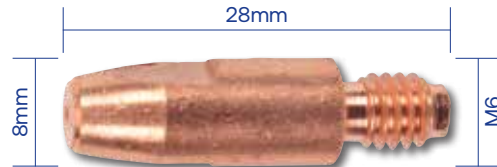

Part No.	Description
P3-BT609	0.9mm Pk5 (ref 140.0169)
P3-BTA609	0.9mm Alu/Flux-Core Pk5 (ref 141.0004)
P3-BT610	1.0mm Pk5 (ref 140.0242)
P3-BTA610	1.0mm Alu Pk5 (ref 141.0006)
P3-BT612	1.2mm Pk5 (ref 140.0379)
P3-BTA612	1.2mm Alu/Flux-Core Pk5 (ref 141.0072)
P3-BT616	1.6mm Pk5 (ref 140.0555)

BZL MIG TIPS

M8x10

- Suit BZL 36, 38 & 501 style MIG torches
- M8 (8mm) thread & 10mm body

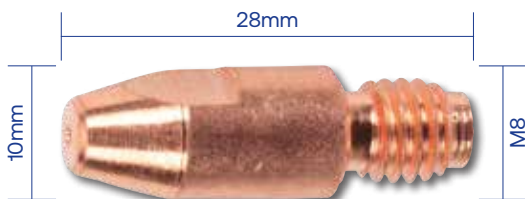

Part No.	Description
P3-BT809	0.9mm Pk5 (ref 140.0214)
P3-BT810	1.0mm Pk5 (ref 140.0313)
P3-BT812	1.2mm Pk5 (ref 140.0442)
P3-BTA812	1.2mm Alu/Flux-Core Pk5 (ref 141.0015)
P3-BT816	1.6mm Pk5 (ref 140.0587)

BZL MIG LINERS

Steel

Note: For Teflon/Aluminium Liners, see epage 76

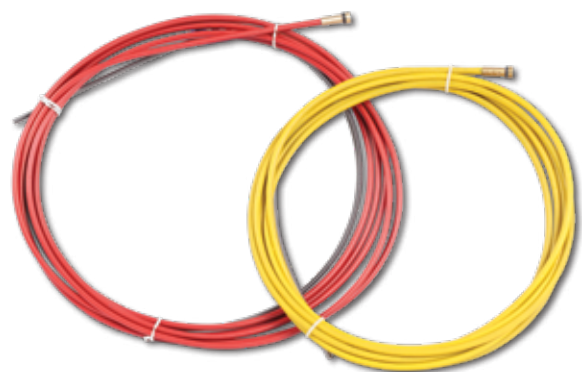

Part No.	Description
P3-BRSL3	0.9 - 1.2mm Red 3m (ref 124.0026)
P3-BRSL4	0.9 - 1.2mm Red 4m (ref 124.0031)
P3-BYSL3	1.2 - 1.6mm Yellow 3m (ref 124.0041)
P3-BYSL4	1.2 - 1.6mm Yellow 4m (ref 124.0042)
P3-BYSL5	1.2 - 1.6mm Yellow 5m (ref 124.0044)

TWC 1

MIG Torch & Parts

- 180 Amp Capacity (150A @ 60% duty cycle, using mixed argon gas)
- Light duty Gas/Gasless torch



Ref	Part No.	Description
-	WC-03957	Complete Torch 3m with Bayonet Connection
A	WC-01653	Consumable Parts Kit
B1	P3-2150	Nozzle Conical 13mm Pk2 (ref 21-50)
B2	P3-170GN	Nozzle Gasless Pk2 (ref KP1939-1)
C	-	Tips - See Page 73
D	P3-170GD	Gas Diffuser Suit Magnum 100L Pk2 (ref 35-50)
	P3-51	Gas Diffuser Suit TWC1 Pk2 (ref 51)
E	P3-454015	Liner for Steel wire 0.8 - 1.2mm (ref 45-40-15)



TWC 2

MIG Torches & Parts

- 250 Amp Capacity
- For medium fabrication



Ref	Part No.	Description
-	3-MTT2E/12	Complete Torch Euro Connection 3.5m (12ft)
-	3-MTT2E/15	Complete Torch Euro Connection 4.6m (15ft)
A	WC-01654	Consumable Parts Kit
B	P3-2250	Nozzle Conical 12mm Pk2 (ref 22-50)
	P3-2262	Nozzle Straight 16mm Pk2 (ref 22-62)
C	P3-32	Insulator Black Pk2 (ref 32)
D	-	Tips - See Page 73
E	P3-52	Gas Diffuser Std Pk2 (ref 52)
	P3-T2HDGD	Gas Diffuser - Fits TWC2, Takes TWC4 Parts (52FN)
F	P3-42404515	Liner for Steel wire 0.9 - 1.2mm (ref 42-4045-15)
-	-	Liner for Aluminium Wire - See Page 76



TWC 4

MIG Torch & Parts

- 400 Amp Capacity (350A @ 60% duty cycle, when using mixed argon gas)
- For medium to heavy fabrication & production welding at high duty cycles



Ref	Part No.	Description
-	3-MTT4E/12	Complete Torch Euro Connection 3.5m (12ft)
-	3-MTT4E/15	Complete Torch Euro Connection 4.6m (15ft)
-	3-MTT4B/12	Complete Torch Bayonet Connection 3.5m (12ft)
-	3-MTT4B/15	Complete Torch Bayonet Connection 4.6m (15ft)
A	WC-01655	Consumable Parts Kit
-	P3-64A45HD	Neck H/Duty 45DG Pk1 (ref 64A-45J)
-	P3-64A60HD	Neck H/Duty 60DG Pk 1 (ref 64A-60J)
B1	P3-24CT62S	Nozzle H/Duty Conical 16mm Pk2 (ref 24CT-62S)
B2	P3-2362	Nozzle Self-Insulated 16mm Pk2 (ref 23-62)
B3	P3-24A62	Nozzle Std Push-On 16mm Pk2 (ref 24A-62)
B4	WC-TW24AT37SSP	Nozzle Std Push-On Tapered 10mm Pk2 (ref 24AT-37SS)
C1	P3-34CT	Insulator H/Duty Copper Pk2 (ref 34CT)
C2	P3-34A	Insulator Std Black Pk2 (ref 34A)
D	-	Tips - See Page 73
E	P3-54A	Gas Diffuser / Tip Holder pK2 (ref 54A)
F	P3-44354515	Liner for Steel wire 0.9-1.2mm (ref 44-3545-15)
	P3-4411615	Liner for Steel wire 1.2-1.6mm (ref 44-116-15)
	P3-4456415	Liner for Steel wire 1.6-2.0mm (ref 44-564-15)
-	-	Liner for Aluminium Wire - See Page 76



TWC MIG TIPS

TWC 1

- Suit TWC 1 & Lincoln Magnum 100L style MIG torches



Part No.	Description
P3-t123	0.6mm Pk5 (ref t1-23)
P3-t130	0.8mm Pk5 (ref t1-30)
P3-t135	0.9mm Pk5 (ref t1-35)
P3-t140	1.0mm Pk5 (ref t1-40)
P3-t145	1.2mm Pk5 (ref t1-45)



TWC MIG TIPS

TWC 2/4

- Suit TWC 2 & 4 style MIG torches
- Heavy duty style with thicker body for longer life



Part No.	Description
P3-1430	Std 0.8mm Pk5 (ref 14-30)
P3-14H35	H/D 0.9mm Pk5 (ref 14H-35)
P3-14H40	H/D 1.0mm Pk5 (ref 14H-40)
P3-14H45	H/D 1.2mm Pk5 (ref 14H-45)
P3-14H52	H/D 1.2mm Alu/Flux-Core Pk5 (14H-52)
P3-14H116	H/D 1.6mm Pk5 (ref 14H-116)

TWC MIG TIPS

TWC 2/4 Tapered

- Suit TWC 2 & 4 style MIG torches
- Tapered ("pipeline") style



Part No.	Description
WC-TW14T35P	0.9mm Pk5 (ref 14T-35)
WC-TW14T45P	1.2mm Pk5 (ref 14T-45)
WC-TW14T116P	1.6mm Pk5 (ref 14T-116)

BND 300

MIG Torches & Parts

- 300 Amp Capacity
- For medium to heavy fabrication & production welding at high duty cycles



Ref	Part No.	Description
-	3-MTBN3E/12	Complete Torch Euro Connection 3.5m (12ft)
-	3-MTBN3E/15	Complete Torch Euro Connection 4.6m (15ft)
A	WC-01656	Consumable Parts Kit
-	P3-4786	Neck / Body Tube 45DG Pk1 (ref BE4786)
B	P3-4391	Nozzle 16mm Pk2 (ref BE4391)
	P3-4392	Nozzle 13mm Pk2 (ref BE4392)
C	-	Tips - See Page 75
D	WC-BE4335P	Head Assembly / Tip Holder / Gas Diffuser Pk2 (ref BE4335)
E	P3-43115	Liner for Steel Wire 0.9-1.2mm (ref BE43115)
-	-	Liner for Aluminium Wire - See Page 76



BND 400

MIG Torches & Parts

- 400 Amp Capacity
- For medium to heavy fabrication & production welding at high duty cycles



Ref	Part No.	Description
-	3-MTBN4E/12	Complete Torch Euro Connection 3.5m (12ft)
-	3-MTBN4E/15	Complete Torch Euro Connection 4.6m (15ft)
A	WC-01657	Consumable Parts Kit
-	P3-4790	Neck / Body Tube 45DG Pk1 (ref BE4790)
B	P3-4491	Nozzle 19mm Pk2 (ref BE4491)
	P3-4492	Nozzle 14mm Pk2 (ref BE4492)
C	-	Tips - See Page 75
D	WC-BE4435P	Head Assembly / Tip Holder / Gas Diffuser Pk2 (ref BE4435)
E	P3-44115	Liner for Steel Wire 0.9-1.2mm (ref BE44115)
-	-	Liner for Aluminium Wire - See Page 76



BND MIG TIPS

BND 300/400

- Suit BND 300A & 400A torches
- Twist-Lock style



Part No.	Description
P3-7488	Contact Tip 0.8mm (ref BE7488)
P3-7489	Contact Tip 0.9mm (ref BE7489)
P3-7496	Contact Tip 1.0mm (ref BE7496)
P3-7490	Contact Tip 1.2mm (ref BE7490)
P3-7498	Contact Tip 1.2mm Alu/Flux-Core (ref 7498)
P3-7491	Contact Tip 1.6mm (ref BE7491)

EURO CONNECTOR KIT

Machine Side

- Replacement kit for Euro connection assembly on front of MIG welding machines & wire feeders



Part No.	Description
3-BGAK	Euro Connector Kit (for front of Welding Machine & Wire Feeders)

SPOOL GUNS

To Suit Weldclass Machines

- Takes BZL 25 series front-end parts see page 69
- 230A capacity
- Note: Plug and plug wiring configuration is configured to suit the Weldclass models indicated and will not suit other machine brands

Application:

- Ideal for use where longer reach is required, from machine to the job
- Due to very short wire travel distance also a popular choice when using aluminium and/or smaller-diameter wires that can be prone to wire feeding difficulty when using conventional torches



Part No.	Description	Suit Weldclass Machine Models
WC-06610	BZL 25 5m with 4-pin plug	160MST MK2, 180MST MK2, 200MST
WC-06203	BZL 25 8m with 9-pin plug	205MST, 255MST, 290MST, 350MST, 395MST

LINERS FOR ALUMINIUM

Universal Series

- For Aluminium wire
- Suits almost any MIG torch: Supplied with fittings to suits all common torch connections: Binzel/Euro, Tweco/Bayonet & Bernard/QD/EZ.
- Premium polymer material for long wear life and resistance to splitting
- Supplied with brass neck liner
- Suits all lengths of MIG torches up to 5m: Simply cut to correct length



Many liners in one -
Save time & hassle!

Part No.	Description
P3-CTUL09	For 0.9/1.0 Aluminium Wire Suit Torches up to 5m Long
P3-CTUL12	For 1.0/1.2/1.6mm Aluminium Wire Suit Torches up to 5m Long

LINERS FOR ALUMINIUM

Suit Long Torches

- For Aluminium wire
- Suit torches with Euro style connection
- Suitable for torches up to 10m Long, especially Push-Pull torches
- Premium polymer material for long wear life and resistance to splitting
- Supplied with brass neck liner



Ideal for Push-Pull Torches!

Part No.	Description
P3-CTL12/t1	For 1.0/1.2/1.6mm Aluminium Wire Suit Torches up to 10m Long

TIG TORCHES & SPARES



TIG TORCH PARTS

17/18/26 Series

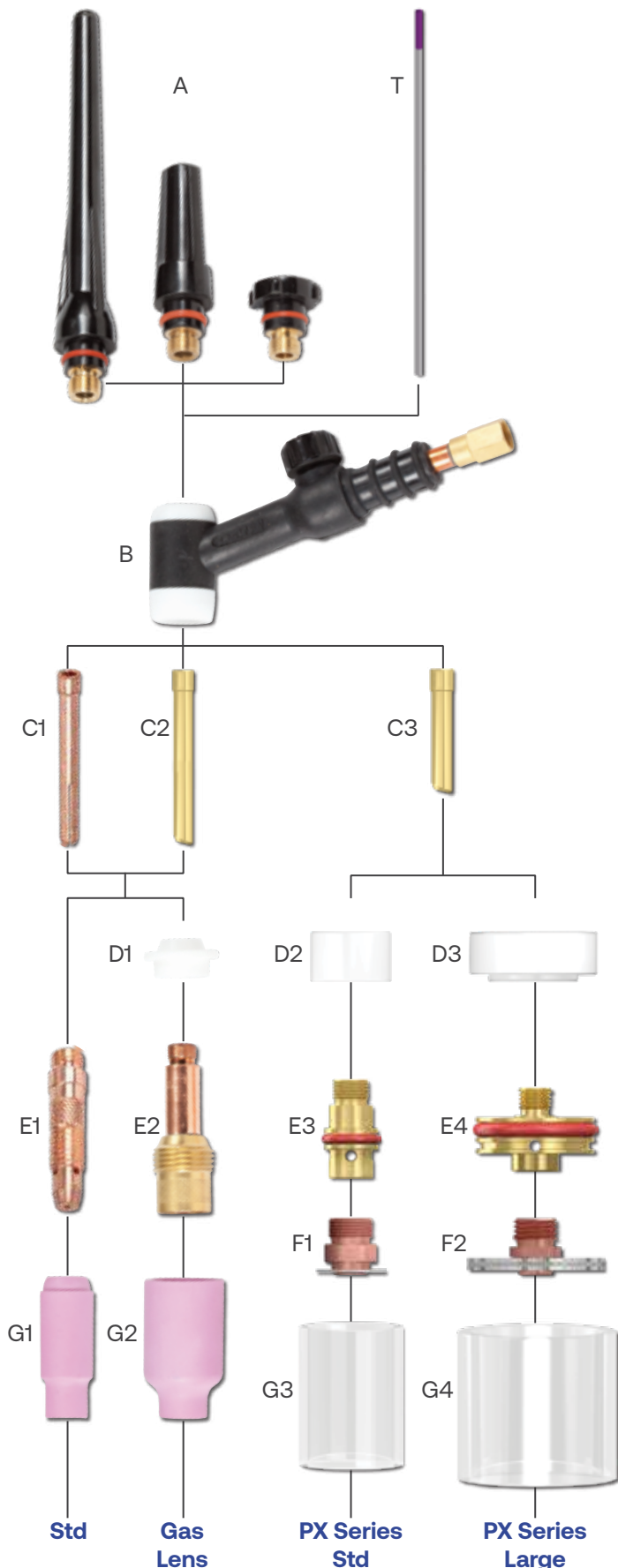

Ref	Item	Size / Details	Part No.
T	Tungsten Electrode	See page 82	
A	Back Cap	Long Pk2	WC-57Y02P
		Medium Pk2	WC-57Y05P
		Short Pk2	WC-57Y04P
B	Torch Body	17F Flexi no valve	P3-TB17F
		17FV Flexi with valve	P3-TB17FV
		26F Flexi no valve	P3-TB26F
		26FV Flexi with valve	P3-TB26FV
		18F Water-cooled	P3-TB18F
C1	Collet Std	1.6mm Pk2	P3-10N23
		2.4mm Pk2	P3-10N24
		3.2mm Pk2	P3-10N25
C2	Wedge* Collet Std	1.6mm Pk2	WC-01843
		2.4mm Pk2	WC-01844
		3.2mm Pk2	WC-01845
C3	Wedge* Collet Stubby	1.6mm Pk2	WC-01840
		2.4mm Pk2	WC-01841
		3.2mm Pk2	WC-01842
*Wedge collets provide reliable clamping of the tungsten vs standard 'split' collets that are prone to twisting when subject to heat / prolonged use			
D1	Gasket	For gas lens Pk2	WC-54N01P
D2		PX Std Pk1	WC-01839
D3		PX Large Pk1	WC-01849
E1	Collet Body Std	1.6mm Pk2	P3-10N31
		2.4mm Pk2	P3-10N32
		3.2mm Pk2	P3-10N28
E2	Gas Lens Collet Body*	1.6mm Pk2	WC-45V25P
		2.4mm Pk2	WC-45V26P
		3.2mm Pk2	WC-45V27P
E3	Collet Body / Diffuser Holder	PX Std Pk1	WC-01846
E4		PX Large Pk1	WC-01847
F1	Diffuser / Gas Lens*	PX Std 1.6mm Pk1	WC-01833
		PX Std 2.4mm Pk1	WC-01834
		PX Std 3.2mm Pk1	WC-01835
		PX Large 1.6mm Pk1	WC-01836
F2		PX Large 2.4mm Pk1	WC-01837
		PX Large 3.2mm Pk1	WC-01838
*Gas lens parts incorporate a fine mesh gas filter for low-turbulence and smooth, linear gas flow to improve weld quality and allow longer tungsten stick-out			
G1	Ceramic Cup Std	#05 7.9mm Pk2	P3-10N49
		#06 9.5mm Pk2	P3-10N48
		#07 11.1mm Pk2	P3-10N47
		#08 12.7mm Pk2	P3-10N46
		#10 15.8mm Pk2	P3-10N45
G2	Ceramic Cup For gas lens	#6 9.5mm Pk2	WC-54N16P
		#7 11mm Pk2	WC-54N15P
		#8 12.7mm Pk2	WC-54N14P
G3	Glass Cup	PX Std Ø14mm Pk1	WC-01831
G4		PX Large Ø29mm Pk1	WC-01832

TIG PARTS KITS

17/18/26 Series

- Fit to any 17/18/26 series torch
- All-in-one, ready-to-weld kits: includes all parts needed to fit to torch head & start welding
- Includes 1.6/2.4/3.2mm tungsten electrodes
- Compact storage case easily fits in a toolbox or hangs on pegboard
- Images and part numbers for easy identification and re-ordering



WC-01660 Std

TIG GLASS CUP KITS

Platinum PX 17/18/26 Series

- High-temperature glass cups provide superior arc visibility
- Fit to any 17/18/26 series torch
- All-in-one, ready-to-weld kits: includes all parts needed to fit to torch head & start welding
- Mesh / gauze filter for smooth gas flow, improves weld quality and allows longer tungsten stick-out
- Wedge collet system provides reliable clamping of tungsten



WC-01662 Std



WC-01661 Gas Lens



WC-01663 Large

Part No.	Description
WC-01660	Std 1.6/2.4/3.2mm
WC-01661	Gas Lens Series 1.6/2.4/3.2mm

Part No.	Description
WC-01662	Standard (Ø14mm Cup) 1.6/2.4/3.2mm
WC-01663	Large (Ø29mm Cup) 1.6/2.4/3.2mm

TIG TORCHES STANDARD

17 & 26 Series with valve

- Suits most inverter welders that have a 'basic/standard' lift-TIG function
- For use on machines that don't have internal TIG gas line/fitting, and where gas hose on torch is connected directly to gas bottle/regulator
- Valved head for gas on/off control at the torch handle
- Flexible torch neck allows torch head to be moulded to the optimum welding position
- Includes ready-to-weld parts kit

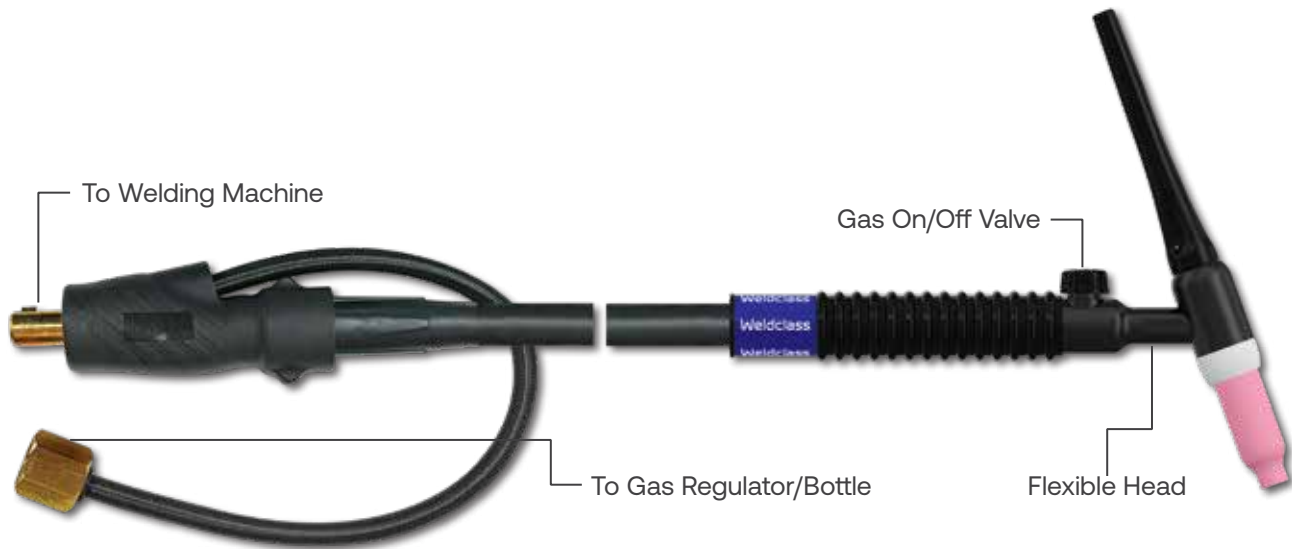

Part No.	Description	Use with/for
WC-00992	#17FV (150 Amp) 4m With 10-25 & 35-50 Connections	Standard inverter machines 130A-250A+ Tungsten electrodes up to 2.4mm Welding materials up to ~3mm thickness
WC-01046	#26FV (200 Amp) 4m with 35-50 Connection	Standard inverter machines 180A-250A+ Tungsten electrodes up to 3.2mm
WC-01046	#26FV (200 Amp) 8m with 35-50 Connection	Welding materials up to ~4-5mm thickness

Typical Set Up

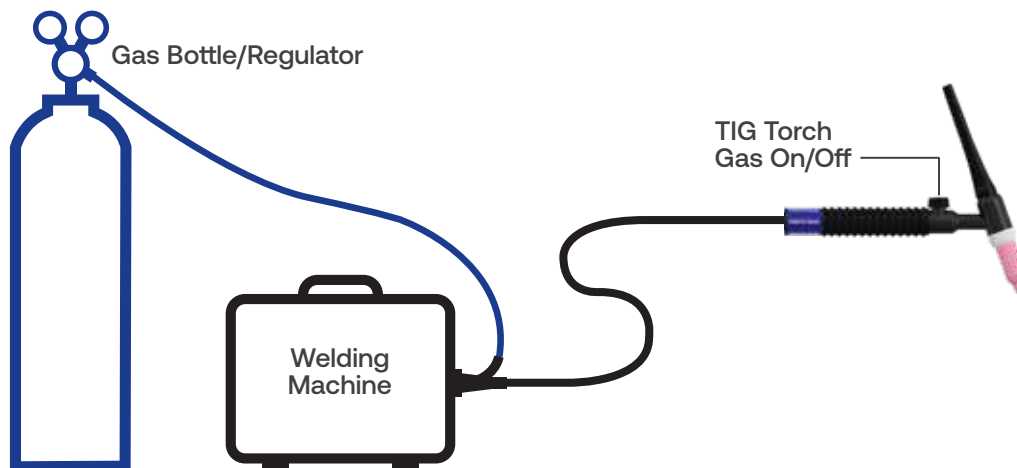

TIG TORCHES SUPER-FLEX

Platinum TK Series

- For use on professional TIG welders (typically AC/DC machines) where gas is routed through the machine
- Where a lightweight, flexible and slimline torch is preferred for maximum dexterity & control
- Often used where operator is using a foot pedal (as all controls are via the foot pedal, switch on the torch is not required)
- Optional trigger kit allows torch to be used independently of foot pedal if required (note: switch does NOT include plug and must be retro-fitted by the user)

Includes:

- Super-Flex 1-piece braided cable
- Cylindrical low-profile torch handle
- Flexible torch head
- Large 35-50 male connector (Ø13mm) to suit most welders 180-200A & above
- Range of gas fittings (including quick-connect) to suit most machine brands
- 1.6mm tungsten & parts

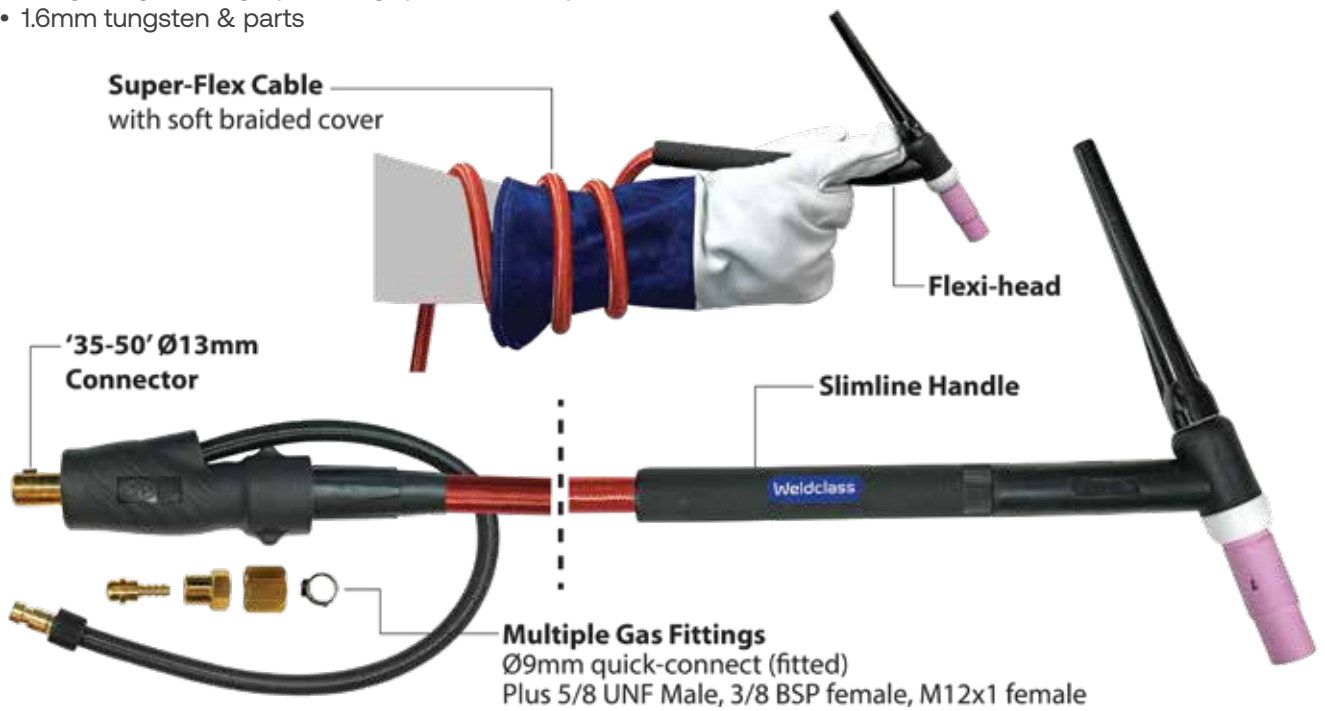

Part No.	Description
WC-04997	PLATINUM TK17 Super-Flex 4m (150 Amp)
WC-01807	PLATINUM TK18 Super-Flex 8m Water-Cooled (350 Amp)
WC-01810	Trigger Kit Suit TK17 Torch
WC-01811	Trigger Kit Suit TK18 Torch

TK18
Water-Cooled
Version



Typical Set Up

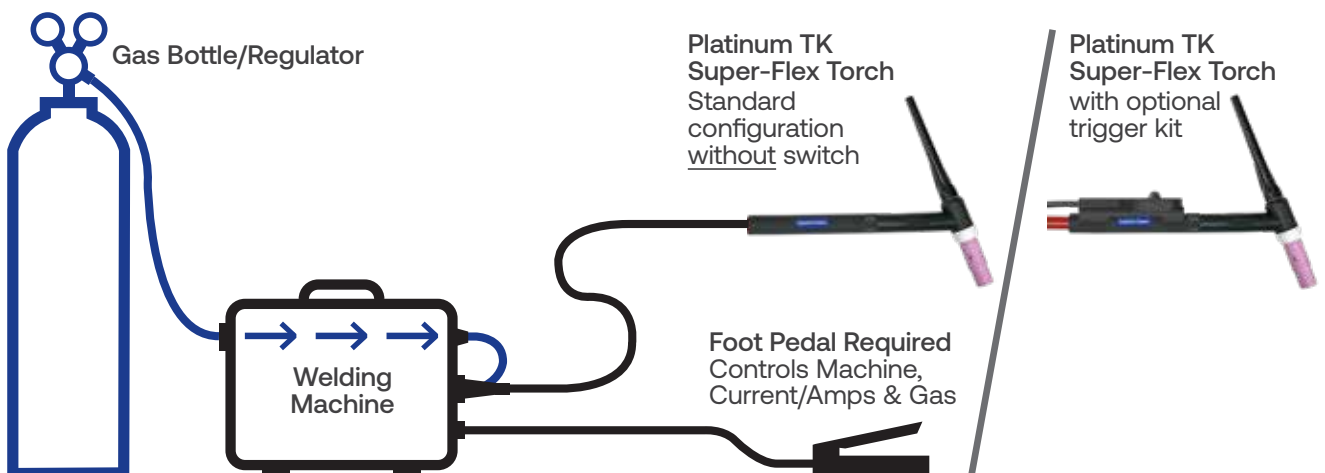

TIG TORCHES SPECIALISED

For Specific Weldclass Machines

- With switch and remote amperage controls on handle
- Note that control plug type & wiring configuration is bespoke to suit the Weldclass machine models indicated & will not suit other machine brands



Part No.	Description	Suits Machine Models
WC-06234	#17 (150A) 4m	205MST, 255MST, 290MST, 350MST, 395MST
WC-06244	#17F (150A) 8m	201T & 203T AC/DC
WC-06248	#26F (200A) 8m	201T & 203T AC/DC
WC-01808	#18F (350A) Water-Cooled	201T & 203T AC/DC, requires water-cooler
WC-06371	#26F (200A) 8m	202T AC/DC

Typical Set Up

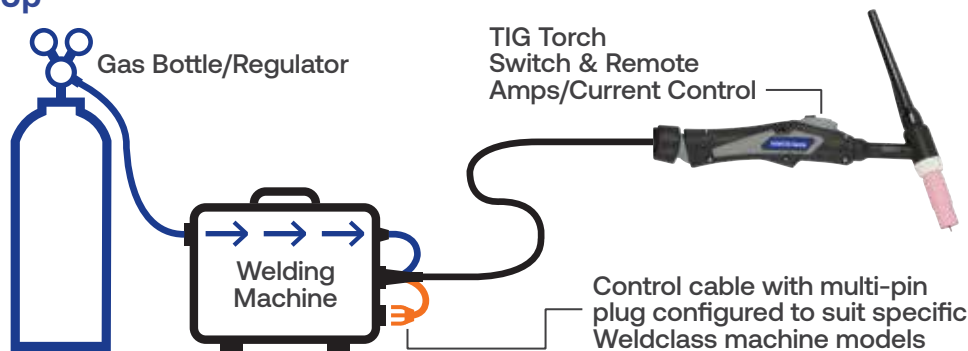

TIG TUNGSTENS

Platinum RE4 AC/DC for All Metals

- “All metal” Tungsten suitable for DC & AC TIG welding
- For DC welding of mild steel, stainless steel, copper and chromoly
- For AC TIG welding of: Aluminium alloys and Aluminium bronze
- Does Not contain radioactive elements = No special safeguards required for use, storage or transport
- Maintains tip geometry, reliable arc striking, low burn off rate, long service life and smooth/stable arc
- Compared to other Tungsten formulas: Requires less energy to start, runs cooler, greater longevity, greater current capacity.



“I have tried other brands & types... with these rods I seem to be able to weld better and the tip stays intact”

- Brendan, WA



Part No.	Description
WC-05192	1.6mm Purple Tip Pk10
WC-05193	2.4mm Purple Tip Pk10
WC-05194	3.2mm Purple Tip Pk10
WC-06509	Blister / Handy Pack 1pc 1.6mm & 1pc 2.4mm

PLASMA TORCH SPARES



XTP 40/60

Plasma Torch Parts



		Suits / Compatible with / Cross Reference Codes					
#	Part No.	Description	Weldclass 40P/41PA/43P/45P (XTP 40/60 Torches)	Cigweld CutSkill 35/45/60, EasyCut	Unimig Viper Cut 30 (SC30 Torch)	Lincoln Invertec PC210 (LC25 Torch)	Bossweld P60, X-CUT 15.0, X-CUT 30.0 (PT40/60 Torches)
-	WC-01658	Parts Kit with Roller Guide	✓ Includes ↓		✓	✓	✓ (PT60 only)
1a	WC-06028	Electrode	✓ x5		✓ WGSC2504	✓ KP2842-1	✓ 96.52582 (PT60 only)
1b	WC-06457	Electrode		✓ CSP337003			
2	WC-06031	Swirl Ring	✓ x1	✓ CSP337007	✓ WGSC2506	✓ KP2842-4	✓ 96.60028
3a	WC-06029	Tip 0.9mm 30-40A*	✓ x5		✓ WGSC2520-09	✓ KP2842-2	✓ 96.51318.09
3b	WC-06459	Tip 0.9mm 30-40A*		✓ CSP337001*, CSP337002			✓ 96.PD0116-09 (PT40 only)
4a	WC-06032	Cap 6-Hole Std	✓ 40/43/45P x1	✓ CSP337005	✓ WGSC2530	✓ KP2842-3	✓ 96.60389
4b	WC-06458	Cap 4-Hole Special	✓ 41PA only				
5	WC-06033	Spacer	✓ 40/45P only x1	✓ CSP337004	✓ WGSC2540	✓ KP2842-5	✓ 96.60432
6	TJ1562	Roller Guide	✓ x1	✓	✓ WGSC2551	✓	✓ 96.TJ1536
7	TJ1202R	Circle Guide	✓	✓ CSP337041	✓ WGSC2550	✓	✓ 96.51866

*0.9mm tips can be used in place of 0.8mm or 1.0mm in most 30-40A applications

GAS GEAR



PLATINUM SERIES

Oxy Kits

- Heavy duty Platinum series cutting, welding and brazing kits
- 7 year warranty offer on regulators, blowpipe handle and cutting attachment
- Bonus combination circle/roller guide
- Robust stainless steel tool box with plenty of space



KIT CONTAINS:

Oxygen Regulator, Acetylene/LPG Regulator, Blowpipe Handle, Cutting Attachment, Brazing Mixer, 3 Brazing Tips, 3 Cutting Tips, 10m Hose Set, Tip Cleaners, Flint Lighter, Combination Circle/Roller Guide, Shade 5 Oxy Specs, Multipurpose Spanner, Set of 4 Flashback Arrestors.



Part No.	Description
4-OXACK	Oxy/Acetylene
4-OXLPG	Oxy/LPG

PLATINUM SERIES

Gas Regulators



Quality without shortcuts

Designed and manufactured by a team with over 40 years' experience in gas equipment engineering.

Peace of mind

Proven reliability. Complies with AS4267. Individually QC Tested. Date stamped for periodic testing in accordance with AS4839.

One-piece encapsulated seat with sintered filter

Superior performance & reliability vs traditional seat designs. Smoother & more consistent flow/pressure delivery. Improves weld quality and reduces troubleshooting issues exacerbated by inconsistent gas delivery.



Internal pressure relief safety valve*

Protects from overpressure hazard. Built into regulator body to protect from contamination, damage & tampering, and ensure reliable operation.

*Applies to Oxygen & Argon/CO2 models only.





PLATINUM SERIES

Gas Regulators - Cont'd

MIG/TIG Welding Series (Shielding Gases)



Argon
0-28Lpm
4-AR1



Argon w/ Flowmeter
0-15Lpm 4-ABFR15
0-25Lpm 4-ABFR25
Flowmeter Only
0-15Lpm 4-BF15
0-25Lpm 4-BF25



CO2
0-28Lpm
4-CO2R1

Oxy/Fuel Series



Oxygen
0-1,000 kpa
4-OXR1



Acetylene
0-150 kpa
4-ACR1



LPG
0-300 kpa
4-LPR1

Nitrogen Series



Nitrogen
0-5,000 kpa
WC-03401



Nitrogen EHP
0-28,000 kpa
WC-03400

Specifications

Part No	Gas	Type	Max Inlet	Max Output	Inlet Connection (Per AS2473)	Outlet Connection (Male)
4-OXR1	Oxygen	Twin-Gauge	30,000 Kpa	1,000 Kpa	Type 10.5	5/8" UNF RH
4-ACR1	Acetylene	Twin-Gauge	4,000 Kpa	150 Kpa	Type 20	5/8" UNF LH
4-LPR1	LPG	Single-Gauge	2,500 Kpa	300 Kpa	Type 21	5/8" UNF LH
4-AR1	Argon	Twin-Gauge	30,000 Kpa	28L/min	Type 10	5/8" UNF RH
4-ABFR15	Argon	With Bobbin Flowmeter	30,000 Kpa	15L/min	Type 10	5/8" UNF RH
4-ABFR25				25L/min		
4-BF15	Argon	Flowmeter Only	-	15L/min	5/8" UNF RH	5/8" UNF RH
4-BF25				25L/min		
4-CO2R1	CO2	Twin-Gauge	30,000 Kpa	28L/min	Type 30	5/8" UNF RH
WC-03401	Nitrogen	Twin-Gauge	22,000 Kpa 220 bar 3,190 psi	5,000 Kpa 700 psi	Type 50	7/16" JIC RH
WC-03400	Nitrogen	Twin-Gauge, Piston Sensing	40,000Kpa 400 bar 5,800psi	28,000 Kpa 280 Bar 4,000 psi	Type 50 & Type 51	7/16" JIC RH

FLASHBACK ARRESTORS

Medium Flow Rated

- Conform to AS4603-1999 & EN ISO 5175-1
- Individually flashback, flow & leak tested
- Independently certified
- Thermal cut off valve for protection against sustained flashback (Regulator Models)
- Up to 35% higher flow capacity*
- Suitable for a broad range of applications, including: cutting, gouging, brazing, medium-to-heavy heating**

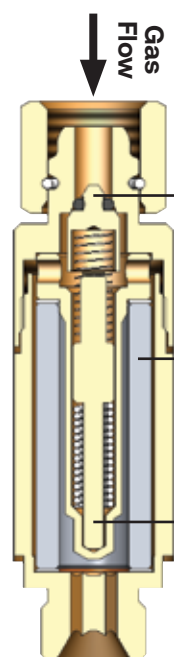

Non-Return Valve
Prevents the passage of gas in the opposite direction to normal gas flow.

Flame Arrestor
A sintered stainless-steel filter (which all gas must pass through) - blocks the flame.

Thermal Cut-Off Valve
(Regulator Models only)
If the arrestor overheats this valve will activate and permanently shut off the flow of gas in any direction. This can occur in the event of repeated or continuous flashback.

Part No.	For	Gas
P4-FBARF2	Regulator	Acetylene / LPG
P4-FBARO2		Oxygen
P4-FBATF	Torch	Acetylene / LPG
P4-FBATO		Oxygen

*Vs some other brands of standard model arrestors. **Max recommended torch/tip oxygen gas consumption of 500L/min. For very heavy heating applications exceeding this, high-flow arrestors are recommended.

QUICK COUPLINGS

For Oxy Gear

- Allows equipment to be quickly and safely dismantled/assembled
- Fast change between hoses and different torches
- Complies with ISO7289 / EN561 Standards
- Automatically shuts off when disconnected
- Use for Oxy, Acetylene, LPG, MIG and TIG gas

Part No.	Description	For	Gas
P4-RQCF	Coupler Set	Regulator	Acetylene / LPG
P4-RQCO	Coupler Set		Oxygen / Argon
P4-TQCF	Coupler Set	Torch	Acetylene / LPG
P4-TQCO	Coupler Set		Oxygen / Argon
P4-TQPF	Pin Only		Acetylene / LPG
P4-TQPO	Pin Only		Oxygen / Argon



Regulator Mount

Torch Mount

BLOWPIPE HANDLE

Platinum Series



- Tried, tested & proven quality
- Dual-Stage valves for quick and precise adjustment from fine work through to heavy cutting and heating
- Superior valve design with tension system to prevent accidental adjustment
- Date-stamped for periodic testing as per AS4839



Part No.	Description
P4-BP	Platinum Series

CUTTING ATTACHMENT

Platinum Series



- Tried, tested & proven quality
- Superior valve design with tension system to prevent accidental adjustment
- Stainless-steel lever
- Date-stamped for periodic testing as per AS4839



Part No.	Description
P4-CA	Platinum Series

OXY CUTTING & GOUGING

Tips & Attachments

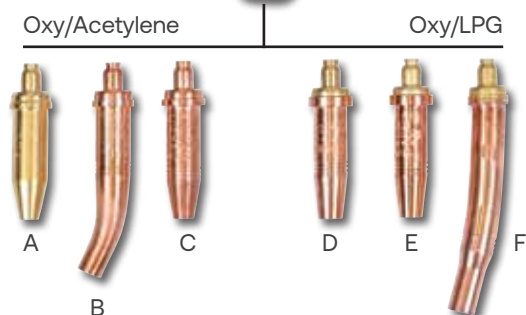
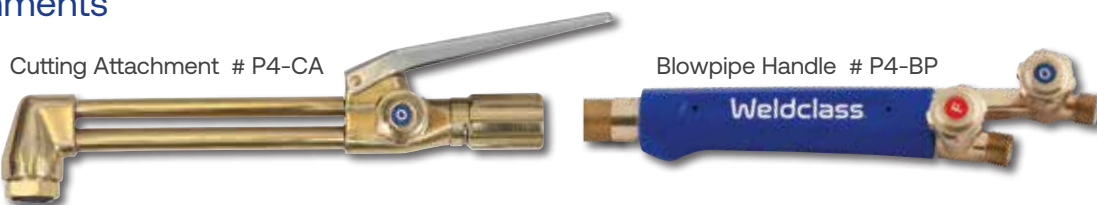

Type	TIPS		Acetylene		LPG		Rec. Approx. Pressure (kpa)	
	Size	Capacity/ Shape	Ref	#	Ref	#	Fuel	Oxy
Cutting	6	1-6mm	A	P4-T416	D	P4-T446	≥ 100	200
	8	6-10mm		P4-T418		P4-T448	≥ 100	200
	12	10-20mm		P4-T4112		P4-T4412	≥ 100	200 - 250
	15	20-75mm		P4-T4115		P4-T4415	≥ 100	350 - 400
Gouging	20	75-125mm		P4-T4120		P4-T4420	≥ 100	400
	32GS	Straight	C	P4-4132GS	E	P4-4432GS	≥ 100	500
	32GB	Bent	B	P4-4132GB	F	P4-4432GB	≥ 100	500
48GB	Bent	P4-4148GB				≥ 100	600	

ROLLER GUIDE

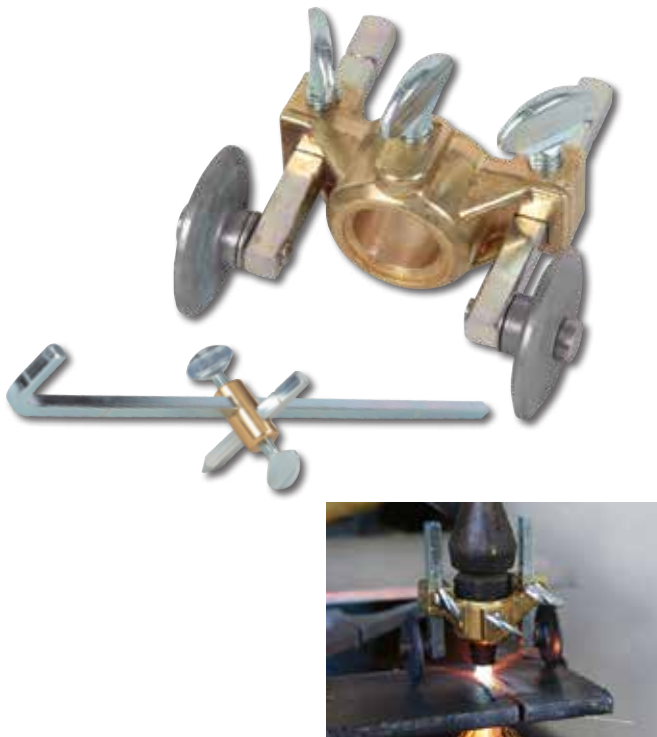

Part No.	Description
P4-TJ1602	Roller Guide Set
P4-TJ6051	Radius Bar - fits TJ4602 Roller Guide to allow circle cutting

CIRCLE GUIDE

- 360 degree cutting from one position
- Height adjustable
- Cuts circles 25-730mm diameter



Part No.	Description
P4-TJ1083	Circle Guide Set
P4-TJ6086	Magnetic Pivot

MACHINE CUTTING

3-Seat Tips

- Suits most straight line & profile cutting machine torches



Oxy/Acetylene
Type 51



Oxy/LPG
Type 54

Size	Steel Thickness	Part No.		Rec. Pressure (kpa)		Cut Speed mm/min
		Acet.	LPG	Oxy	Fuel	
0	<10mm	P4-T510	P4-T540	200	20	660-550
1	10-15mm	P4-T511	P4-T541	280	20	550-490
2	15-30mm	P4-T512	P4-T542	315	20	490-400
3	30-40mm	P4-T513	P4-T543	315	20	400-350
4	40-50mm	P4-T514		315	25	350-320
5	50-100mm	P4-T515		385	35	320-200
6	100-150mm	P4-T516		455	40	200-150

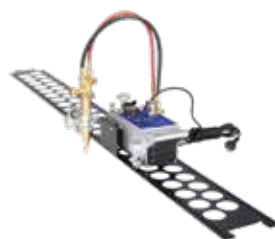

OXY BRAZING

Tips & Attachments

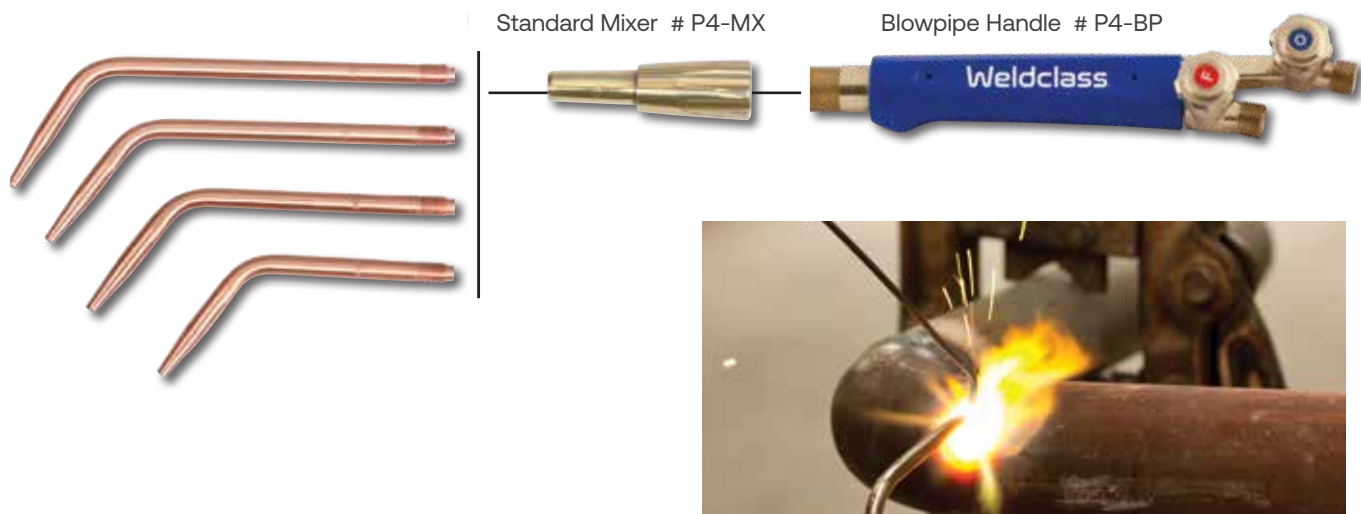

BRAZING TIPS Size	Capacity Max Steel Thickness	Part No.		Rec. Approx. Pressure (kpa)	
		Acet.	LPG	Fuel	Oxy
8	2.0mm	P4-08WT	P4-08WTLP	50	50
10	2.5mm	P4-10WT		50	50
12	4.0mm	P4-12WT	P4-12WTLP	50	50
15	6.5mm	P4-15WT	P4-15WTLP	50	50

OXY HEATING

Tips & Attachments

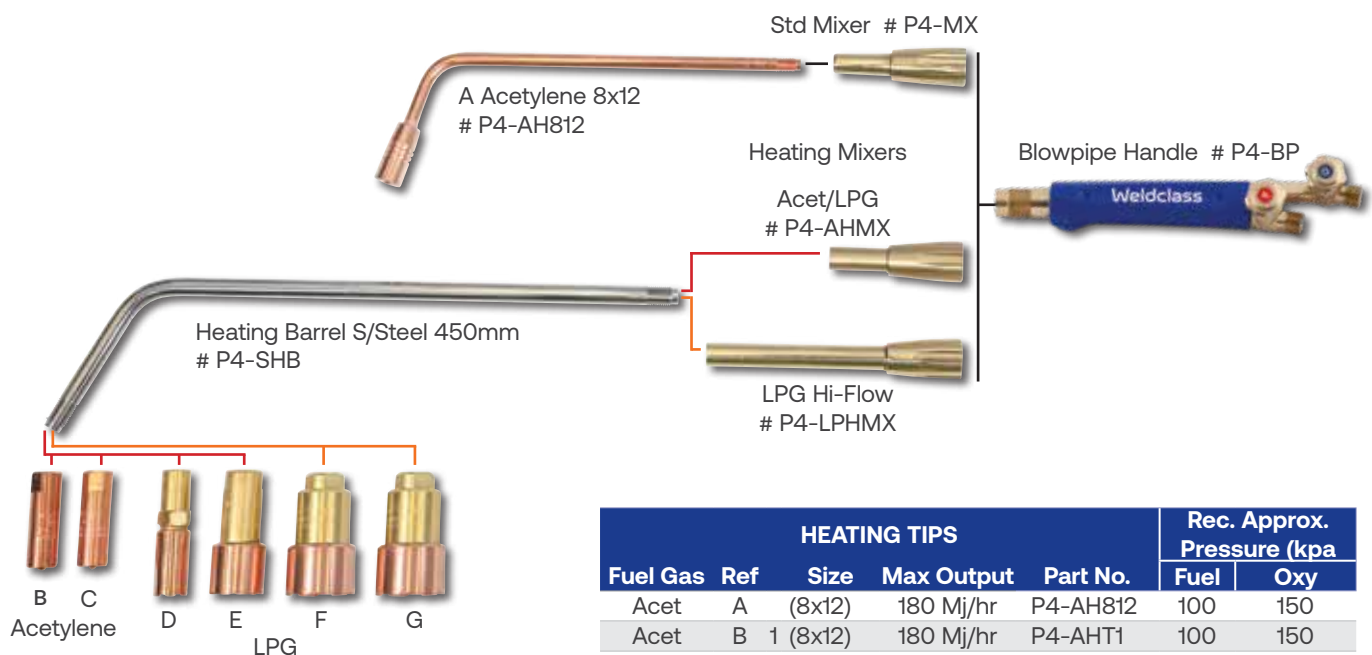

HEATING TIPS					Rec. Approx. Pressure (kpa)	
Fuel Gas	Ref	Size	Max Output	Part No.	Fuel	Oxy
Acet	A	(8x12)	180 Mj/hr	P4-AH812	100	150
Acet	B	1 (8x12)	180 Mj/hr	P4-AHT1	100	150
Acet	C	2 (12x12)	215 Mj/hr	P4-AHT2	100	150
LPG	D	1 (18x12)	280 Mj/hr	P4-LPHT1	100	500
LPG	E	2 (36x12)	420 Mj/hr	P4-LPHT2	100	600
LPG	F	3 (48x12)	560 Mj/hr	P4-LPHT3	100	600
LPG	G	4 (48x15)	840 Mj/hr	P4-LPHT4	300	1,000

PLATINUM LT40 LPG BURNER TORCH

- Air/LPG operation requires LPG gas only (no Oxygen required)
- Robust construction for industrial applications



Impressive Output
Up to 500mj/h (475,000 BTU)
& 1,200mm flame length

Torch Lengths
1,000mm & 600mm

Flame Controls
Heating flame adjustment
Pilot adjustment*
Squeeze trigger*
*(Included on all models, except for Handyflame Kit)

★ **MADE IN EUROPE** ★

7 YEAR WARRANTY OFFER*

Unique Swivel Joint
Eliminates hose torsion/tension

H/Duty Handle
Screwless Single-piece molded design

5/8: UNF
Standard/common connections

Choice of 4 Kits

HANDYFLAME KIT
WC-02988



MAXFLAME KIT
WC-02989



COMBO KIT
WC-02991



TORCH ONLY KIT
WC-02990



Up to 500mj/hr (475,000 BTU) output



Use with standard 4/9/45kg LPG bottle



Metal Heating & Weld Pre-heating



Weed Burning



Bitumen Heating & Concrete Curing



Water-Proofing, Drying & Thawing



Heat Shrinking/ Wrapping



“Very impressed, easy to use, very well made”

- Tony, NSW

PLATINUM LT40 'HANDY FLAME'

Torch Kit

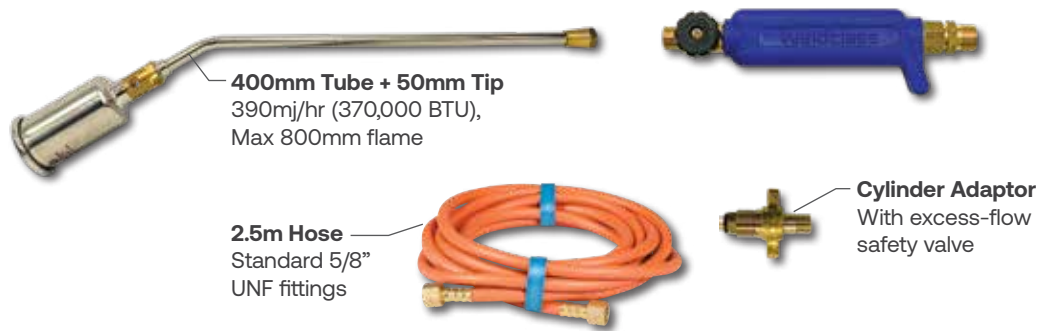

Budget option with good flame power. Operates on full bottle pressure.

Part No.
WC-02988

PLATINUM LT40 'MAXFLAME'

Torch Kit



Operates on full bottle pressure* for maximum heat output & flame size. Includes cylinder adaptor with excess flow safety valve.

*typically 600-1400 kpa depending on ambient temperature

Part No.
WC-02989

PLATINUM LT40 'COMBO'

Torch Kit

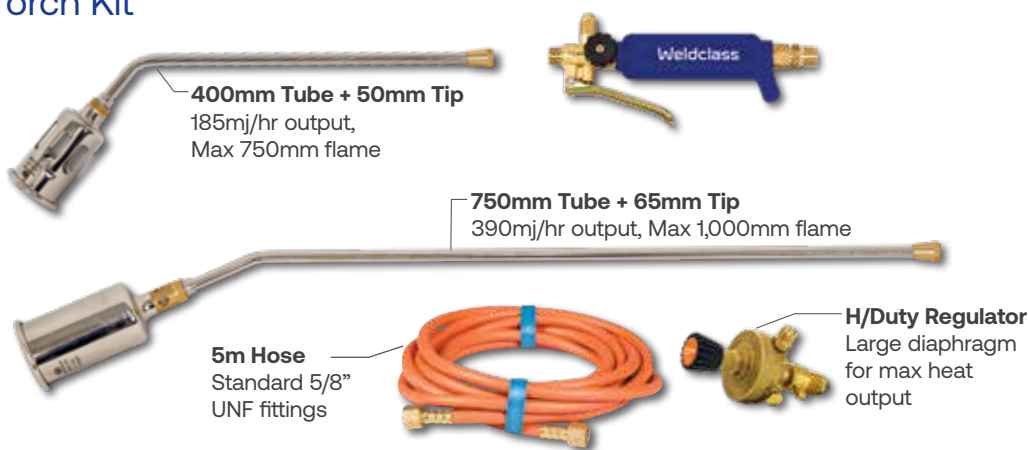

The "all in one" kit with two tube lengths & two tip sizes.

Gas regulator reduces operating pressure to ≤400kpa for reduced gas consumption, more controlled/consistent gas flow & finer flame adjustment.

Part No.
WC-02991

PLATINUM LT40 'TORCH ONLY'

Torch Kit

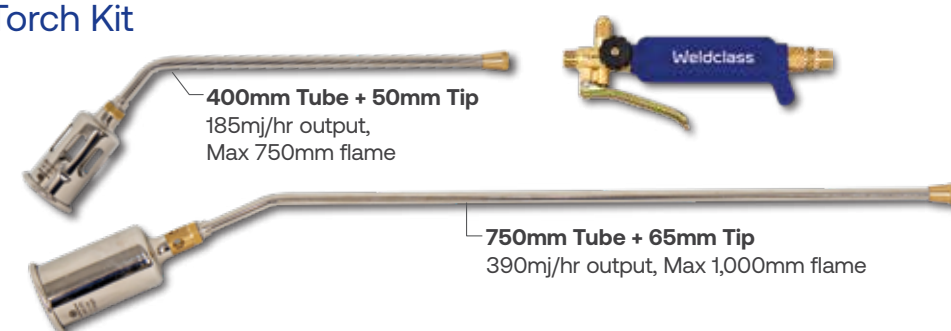

Good choice for fitting to existing hoses & regulator. Includes two tube lengths & two tip sizes.

Part No.
WC-02990

BULK HOSE

- Long life formula
- Ozone resistant and oil resistant
- 5mm I.D.



Part No.	Description	MOQ
4-TWAC5	Oxy/Acetylene (Blue/Red)	100m
4-TWLP5	Oxy/LPG (Blue/Orange)	100m
4-SOX5	Oxygen/Argon/Inert	100m

OXY HOSE SETS

Twin with Fittings

- Long life formula
- Ozone resistant and oil resistant
- 5mm I.D.
- 5/8 UNF Australian standard hose connections



LPG HOSE SETS

Single with Fittings

- Suitable for use with LPG burner/heating torches
- 5/8 UNF LH Connections
- 5mm I.D.



Part No.	Description
4-SLP5M	5m
4-SLP10M	10m

Part No.	Type	Length
4-AC5M	Oxy/Acet (Blue/Red)	5m
4-AC10M		10m
4-AC15M		15m
4-AC20M		20m
4-LP5M	Oxy/LPG (Blue/Orange)	5m
4-LP10M		10m
4-LP15M		15m

MIG/TIG HOSE KITS

For Argon/CO²/ Inert Gases



Ref	Part No.	Description
A	WC-03338	4m with various fittings - Universal kit suits almost any MIG/TIG welder
B	WC-03339	20m with fittings - Cut to desired length & attach fittings as/if required

FLINT LIGHTERS



Part No.	Description
P4-SFL	Single Flint Lighter
P4-SFR	Single Flint Replacements Pk 10
P4-TFL	Triple Flint Lighter
P4-TFR	Triple Flint Replacements Pk 5

TIP CLEANERS

- Abrasive wires remove carbon build up and loose slag from nozzles and tips
- Extra long 125MM tip cleaners are suitable for 3 seat cutting tips



Part No.	Description
P4-TC	Standard 100mm
P4-TCL	Long 125mm

HOSE & GAS FITTINGS

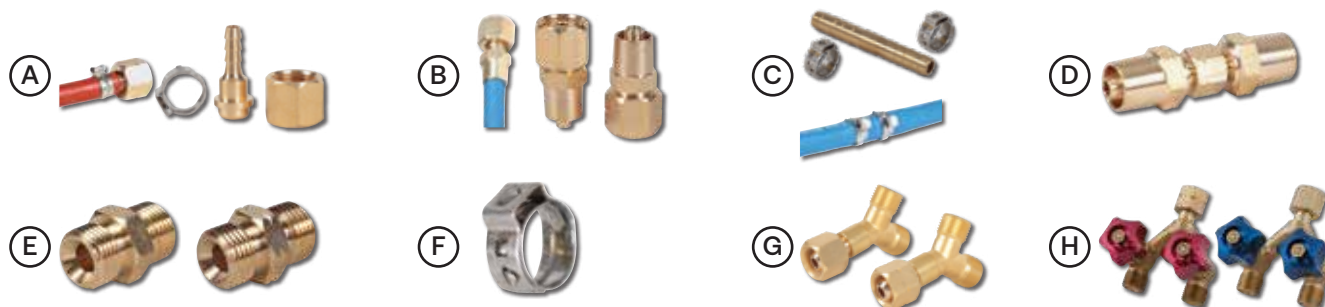

Ref	Part No.	Description	Thread	Gases	Suit Hose Size	Packaging	MOQ
A	P4-RHHCK	Connector Kit Crimp-On	5/8" UNF RH	Oxy/Argon	5mm I.D.	Carded	1
	P4-LHHCK		5/8" UNF LH	Acet/LPG			
	P4-RHHCK10		5/8" UNF RH	Oxy/Argon	10mm I.D.		
	P4-LHHCK10		5/8" UNF LH	Acet/LPG			
B	4-LP112	Connector Screw-On	5/8" UNF RH	Oxy/Argon	5mm I.D.	Bulk	10
	P4-LP112			Acet/LPG		Carded	1
	4-LP240		5/8" UNF LH	Acet/LPG		Bulk	10
	P4-LP240					Carded	1
C	P4-DEBK	Joiner / Double-End Barb Kit	n/a	All	5mm I.D.	Carded	1
	P4-DEBK10						
D	4-LP265	Joiner Screw-On	n/a	All	5mm I.D.	Bulk	10
	P4-LP265					Carded	1
E	4-WB34	Coupler	5/8" UNF RH	All	n/a	Bulk	10
	P4-WB34					Carded	1
	4-WB35		5/8" UNF LH			Bulk	10
	P4-WB35					Carded	1
F	P4-HFC133/10	Hose Clamps	n/a	All	5mm I.D.	Pk10	1
G	P4-R121	Y-Piece	5/8" UNF RH	All	n/a	Carded	1
	P4-R215		5/8" UNF LH				
H	P4-HFYVRH	Y-Piece with Valves	5/8" UNF RH	All	n/a	Carded	1
	P4-HFYVLH		5/8" UNF LH				

LOOKING FOR...

WELDING HELMETS?



Page 19

WELDING BLANKETS?



Page 41

FUME EXTRACTION?



Page 17

ABRASIVES



PROMAX ZR 100%

Flap Discs

For Steel, Stainless & Aluminium

Tried, Tested & Proven
by Aussie fabricators
for over 15 years

OSA Approved
for peace of mind
& conforms to
EN12413 & AS1778.1

100% Zr For Superior Life & Performance
Made with premium 100% Zirconia grit
(many other brands have only 60% or less)

Up to 30% More Grit Cloth
than other brands = Longer life,
fewer disc changes & less
down time



← **Weldclass**
← Other Brand



“Unreal product, a lot better wear and final finish compared to other brands”

- Mick, NSW

Part No.	Description	Pack Qty	Carton Qty
TO-5002	100mm (4") Z40 Grit	10	80
TO-5004	100mm (4") Z60 Grit	10	80
TO-5006	100mm (4") Z80 Grit	10	80
TO-5008	100mm (4") Z120 Grit	10	80
TO-5012	115mm (4.5") Z40 Grit	10	80
TO-5014	115mm (4.5") Z60 Grit	10	80
TO-5016	115mm (4.5") Z80 Grit	10	80
TO-5018	115mm (4.5") Z120 Grit	10	80
TO-5022	125mm (5") Z40 Grit	10	80
TO-5024	125mm (5") Z60 Grit	10	80
TO-5026	125mm (5") Z80 Grit	10	80
TO-5028	125mm (5") Z120 Grit	10	80
TO-5042	180mm (7") Z40 Grit	10	80
TO-5044	180mm (7") Z60 Grit	10	80

PROMAX INOX CUT

Cutting Discs

- Excellent disc life and value for money
- Smooth & Safe Cutting - Unique anti-friction surface on both sides of disc: Improves the ease of the cut, increases cut speed and prevents jamming and kick-back.
- Optimum performance on both Mild and Stainless Steel.
- INOX/Iron-Free for safe use on Stainless Steel



“Other brands have worn down quickly, but these cut well & found them extremely durable”

- Greg, NSW



Part No.	Description	Box Qty
TO-6202	100mm (4") x 1.0mm	50
TO-6204	115mm (4.5") x 1.0mm	50
TO-6206	125mm (5") x 1.0mm	50
TO-6220	125mm (5") x 1.6mm	50
TO-6274	125mm (5") x 2.5mm	25
TO-6224	180mm (7") x 1.6mm	25
TO-6226	230mm (9") x 1.9mm	25

PROMAX INOX CHOP

Chop-Saw Discs

- Excellent disc life and value for money
- For portable 240V Chop-Saws/Cutting saws (Max RPM 4,400)
- Optimum performance on both Mild and Stainless steel
- INOX (Iron-Free) for safe use on Stainless steel



Part No.	Description	Box Qty
TO-6532	350mm 14" x 2.8mm x 25.4mm Bore	10

PROMAX INOX 'FAST' GRIND

Grinding Discs

- Medium hardness for fast grinding of steel & Stainless-steel.
- INOX (Iron-Free) for safe use on Stainless steel.
- Fast metal removal, good disc life and great value for money



Part No.	Description	Box Qty
TO-6122	115mm (4½") x 6.5mm	10
TO-6124	125mm (5") x 6.5mm	10



CUP BRUSHES

Twist-Knot & Crimped

- Made in Europe using high-tensile wire, as used in manufacture of high performance European motor vehicle tyres
- Smooth-action and perfect balance
- Cup shape for flat surfaces, external corners & edges, etc



Ref	Part No.	Size	Wire Type		Suit Grinder Sizes	Thread Size	Max RPM
A	TO-3032	75mm	Twist-Knot	Mild-Steel	100mm+	M14x2 / M10x1.5	14,000 RPM
	TO-3620			Stainless-Steel			
B	TO-3092		Crimped	Mild-Steel (Brass-Coated)			
C	WC-06462	92mm Opti-5*	Twist-Knot	Mild-Steel	125mm+	M14x2	12,200 RPM
	WC-06463			Stainless-Steel			
*Specifically engineered for optimum performance on 125mm/5" angle grinders, see weldclass.com.au/opti5							
D	WC-06464	120mm	Twist-Knot	Mild-Steel	180/230mm	M14x2	8,500 RPM

BEVEL BRUSHES

Twist-Knot & Crimped

- Made in Europe using high-tensile wire, as used in manufacture of high performance European motor vehicle tyres
- Smooth-action and perfect balance
- Cup shape for flat surfaces, external corners & edges, etc



Ref	Part No.	Size	Wire Type		Suit Grinder Sizes	Thread Size	Max RPM
A	TO-3098	100mm	Twist-Knot	Mild-Steel	100mm+	M14x2 / M10x1.5	14,000 RPM
	TO-3610			Stainless-Steel			
B	WC-0645		Crimped	Mild-Steel			
C	WC-04814	125mm Opti-5*	Twist-Knot	Mild-Steel	125mm+	M14x2	12,200 RPM
*Specifically engineered for optimum performance on 125mm/5" angle grinders, see weldclass.com.au/opti5							

PIPELINE WHEEL

Brushes

- 40 knots per wheel for long brush life
- Professional quality: Tempered steel wire, smooth action and perfect balance
- Ideal for pipeline weld bead cleaning; including during root pass, inter-pass, hot pass operations, etc
- Coarse twist knot steel wire for fast removal of slag, spatter & oxidisation
- 22mm Bore/Arbor for use on 5", 7" or 9" angle grinders



“Great long lasting wheels, will continue to purchase for my guys”

- Aaron, QLD

Part No.	Description
TO-3086	125mm x 6mm Twist-Knot Mild-Steel
TO-3670	125mm x 6mm Twist-Knot Stainless-Steel

WHEEL BRUSHES

For Bench Grinders

- For bench / pedestal grinders
- Multi-bore: Includes set of bushes to suit various grinders.
- Professional quality: Tempered steel wire, smooth action
- Brass-Coated crimped (wavy) wire for mild scrubbing action, rust, scale, paint removal, deburring, etc



Part No.	Description
TO-3076	150mm (6") x 19mm
TO-3078	200mm (8") x 25mm

SPINDLE MOUNT

Cup Brushes

- Professional quality: Tempered steel wire, smooth action
- 6.4mm/1/4" Shaft/Spindle
- Brass-Coated crimped (wavy) wire for mild scrubbing action, light rust removal, deburring, etc
- Cup shape for flat surfaces, external corners & edges, etc



Part No.	Description
TO-3050	ø50mm
TO-3052	ø70mm

SPINDLE MOUNT

End Brushes



- Professional quality: tempered steel wire, smooth action
- 6.4mm / 1/4" Shaft/Spindle
- 17mm & 25mm: Brass-Coated crimped (wavy) wire for mild scrubbing action, light rust removal, deburring, etc
- 20mm: Twist-knot wire for coarse action, rust & scale removal, surface preparation, etc
- End shape for narrow areas, internal holes, cavities, cylinders, etc



Part No.	Description
TO-3060	15mm Crimped Brass-Coated Steel
TO-3062	25mm Crimped Brass-Coated Steel
WC-05135	20mm Twist-Knot Mild-Steel

SPINDLE MOUNT

Wheel Brushes



- Professional quality: tempered steel wire, smooth action
- 6.4mm/c" Shaft/Spindle
- 50mm & 75mm: Brass-Coated crimped (wavy) wire for mild scrubbing action, light rust removal, deburring, etc
- 80mm: Twist-knot wire for coarse action, rust & scale removal, surface preparation, etc
- Wheel shape for narrow areas, corners, channels, internal curves, etc



Part No.	Description
TO-3070	50mm Crimped Brass-Coated Steel
TO-3072	70mm Crimped Brass-Coated Steel
TO-3074	70mm Twist-Knot Mild-Steel

HAND BRUSHES

4-Row Wooden Handle

- Long handle for extended reach
- Great value
- Straight wire for heavy-duty action: rust & scale removal, de-sludging, etc
- 4-Row for flat surfaces, outside corners & edges, etc
- 355mm long, 52 tuft



Part No.	Description
TO-3210	Mild Steel
TO-3212	Stainless-Steel

HAND BRUSHES

1-Row



- Ergonomic & long-life design
- Single row curved style - ideal for internal corners, channels, etc
- Crimped (wavy) wire for mild scrubbing action, light rust removal, deburring, etc
- Plastic moulded handle



Part No.	Description	Colour
TO-3202	Brass-Coated Steel	Red
TO-3204	Stainless-Steel	Green

MERCHANDISE



WELDCLASS T-SHIRTS

The genuine Weldclass Tee !
 Just like any other Weldclass product, our T-shirts are designed with care and made to last. Raglan sleeve sports style for comfort and ease of movement. Premium cotton blend fabric that's durable yet cool and comfortable.



Part No.	Description
WC-06510	Navy S
WC-06511	Navy M
WC-06512	Navy L
WC-06513	Navy XL
WC-06514	Navy 2XL
WC-06515	Navy 3XL
WC-06516	Navy 4XL

WELDCLASS STUBBY HOLDER

Fully stitched and ready for your next BBQ!



Part No.
WC-04075

MERCHANDISING & DISPLAYS

Weldclass provides distributors with world class product merchandising & display solutions, that support our mission to 'Make life easier for welders & retailers'. Contact Weldclass for more details.



Weldclass®

ALLCLEAR

FUME CONTROL SOLUTIONS

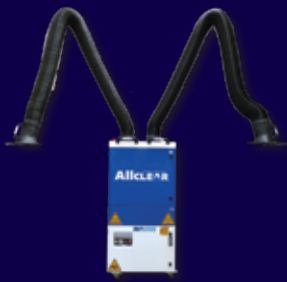

weldclass.com.au/FumeControl

Weldclass®

Ph: 1300 787 400 | E: sales@weldclass.com.au



weldclass.com.au



Your Weldclass Distributor:



9 341562 030007

Part No. WC-03000